

NEW CONSTRUCTION HANDBOOK



Customer Builder Commercial Developer Information



If you have any questions, please contact a Black Hills Energy construction representative in your area.

In Rapid City:

Louie Schwengler
409 Deadwood Ave
Rapid City, SD 57702
605-721-1443
louis.schwengler@blackhillscorp.com

Brian Lewis
409 Deadwood Ave
Rapid City, SD 57702
605-721-2263
brian.lewis@blackhillscorp.com

Justin Almond
409 Deadwood Ave
Rapid City, SD 57702
605-399-5151
justin.almond@blackhillscorp.com

Travis Powrie
409 Deadwood Ave
Rapid City, SD 57702
605-721-2642
travis.powrie@blackhillscorp.com

Luke Ross
409 Deadwood Ave
Rapid City, SD 57702
605-721-1724
luke.ross@blackhillscorp.com

Nathan Woods
409 Deadwood Ave
Rapid City, SD 57702
605-721-2218
nathan.woods@blackhillscorp.com

In the Northern Hills:

Drew Heid
1251 Otter Road
Sturgis, SD 57785
605-206-2967
drew.heid@blackhillscorp.com

Justin Madetzke
1251 Otter Rd
Sturgis, SD
605-206-2964
justin.madetzke@blackhillscorp.com

In the Southern Hills:

Corey Virtue
447 Mt. Rushmore Rd
Custer, SD 57730
605-858-7013
corey.virtue@blackhillscorp.com

Jared Bender
447 Mt. Rushmore Rd
Custer, SD 57730
605-858-7012
jared.bender@blackhillscorp.com

Black Hills Energy

New Commercial Customer Packet

Thank you for contacting Black Hills Energy about your power needs. This packet contains valuable information to help you acquire needed electrical services. Below is an index to the packet.

Contents

General

- Responsibilities for New Commercial Service..... 1
- Property Documents 2

Specifications, etc.

- 1410-SV1 - Requirements for permanent electric service 4
- 1440-TR1 - Instrument metering overhead services 5
- 1440-TR2 - Instrument metering underground services..... 6
- 1440-TR2.1 - Instrument metering pedestal for permanent underground services 7
- 1440-TR2.2 - Manufactured instrument metering pedestal for permanent underground service 8
- 1440-TR3 - 3Ø pad-mounted secondary transition cabinet..... 9
- 1410-SV5 - Self-contained underground permanent service - steel post 10
- 1410-SV8 - Gang meter modules and meter pedestals 11
- 1453 - 3Ø transformer fiberglass base (75, 150, 300, 500, 750,1000 & 1500 KVA) 12
- PT-1 - Pad-mount transformer locations and clearances 13
- PT-2 - Mechanical protection for pad-mounted equipment 14
- 1430-CL1-1430-CL3 - Clearances of service drops 600 volts or less attached to buildings, signs, and other installations 15
- 1430-CL4 - Clearance requirements from gas meters..... 18
- 1420-TM1- Requirements for temporary electric service/construction power 19
- 1420-TM2 - Overhead temporary service 20
- 1420-TM3 - Underground temporary service 21
- TR1-TR4 - Trench specifications without gas 22
- TR5-TR8 - Trench specifications joint with gas 23
- 2210 - URD cable and trench guidelines..... 24-25

Forms

- Grade Agreement 26
- Application and Agreement for Electric Service Extension 27
- New Customer Question List 29
- Customer responsibility check list 30
- Construction Handbook Received 32



Responsibilities for New Commercial Service – BHE/Customer

BHE Responsibility

- A. BHE will supply
 - a. Primary Conductors
 - i. Either overhead or underground
 - ii. Located on Right-of-Way(s) or utility easement.
 - b. Secondary conductors from overhead transformer to point of attachment
 - c. Transformer
 - d. Meter

- B. Installation of the above

Customer Responsibility

- A. Initial Information
 - a. Service Size (voltage, amperage, phase)
 - b. Type of load (gas heat, electric heat, total electric home, demand controller, seasonal, commercial, etc)
 - c. Location of service

- B. Signed Court House copy of following for each parcel crossed. Owner of record may need to sign an easement
 - a. Warranty Deed and Certified Plat (showing book and page)
- OR**
- b. Contract for Deed
 - c. Pay any applicable fees before construction

- C. Sign and return the Electric Service Extension contract

- D. Wiring affidavit sent to State
 - a. Affidavit sticker to be mounted on service

- E. Trench, Conduit and Backfill (for underground cable)
 - a. Proper sized conduit per BHE specifications
 - b. Proper bedding per BHE specifications
 - c. Backfill over bedding

- F. All tree trimming per BHE specifications

- G. Meter base, CT enclosures, meter pedestals, transitions cabinets, and conductors from meter to main panel

- H. Install transformer pad

- I. Furnish and install secondary conductors from underground transformer customer owned facilities

- J. Completion of Grade Agreement



Responsibilities for New Commercial Service Property Documents

Before Black Hills Energy can extend our power lines to your new commercial service we need to have permission to build on your property and possibly your neighbor's property. The permission would be either in the form of an already existing "easement" or a signed "Easement".

Existing Utility Easement

A utility easement gives a utility the right to place their equipment on your property within the easement. There may be an existing easement on or near your property. The easement may be located along roads, along lot lines or as other defined areas. Easements come in the form of drawn easements or described (written) easements. If your property is in a "platted" development, existing utility easements may be shown or noted on a document known as a plat. The official plat is located at your county court house in the **Register of Deeds**.

If your property has not been platted it is known as "described" property. Easements for described property may also be in the form of drawn easements or as described (written) easements.

Easements on both described and platted properties may be shown or noted either on a drawn or described (written) "exhibit". This document may be filed as a "miscellaneous document".

If it is unknown whether a utility easement exists on your property a search may need to be done in the Register of Deeds.

Signed Easement

If a utility easement does not exist, an Easement needs to be produced and signed. An Easement gives a utility the right to place their equipment on your property. The Easement document may be produced using copies of existing plats or described property as found in the **Register of Deeds**. Any Easement needs to be signed by the owner of the property. In the case of a Contract for Deed the Easement needs to be signed by the person(s) selling the property and the person(s) purchasing the property through the contract. BHE will provide the needed Easement form for you to use to either execute an Easement or obtain one from neighboring property owners that the power line will need to cross.

In order for Black Hills Energy to know who owns the property our power lines will cross to serve you, a deed is also needed from the Register of Deeds. A deed can be in the form of a Warranty Deed, a Quitclaim Deed or a Contract for Deed. Any of these show who the owner or owners are of platted or described real estate.

Warranty Deed

This document names the current owner(s) and who the property was purchased from. The Warranty Deed also describes exactly what property is owned. The official Warranty Deed is located at your county courthouse in the **Register of Deeds**.

Quitclaim Deed

This document names the current owner(s) and who the property was purchased from. The Quitclaim Deed also describes exactly what property is owned. The official Quitclaim Deed is located at your county courthouse in the **Register of Deeds**.

Contract for Deed

This document names the current owner(s) and who is currently purchasing the property. The Contract for Deed also describes exactly what property is owned. The official Contract for Deed is located at your county courthouse in the **Register of Deeds**.

It is the responsibility of the person requesting new electrical service to gather the required documents from the county courthouse. For every separate piece of real estate crossed by the new electric extension a copy of the deed,

as described above, needs to be supplied to BHE. If the real estate noted on the deed copy has been platted then another document, a plat (copy of), is also required from the courthouse.

There are two ways for you to gather the documents needed for Black Hills Energy to extend our power lines to your new service.

Do it Yourself

The first way is for you to go to the courthouse to find and purchase copies of the Deed(s) and/or Plat(s). This may take the least out-of-pocket money but may also take the most time.

Hire it done

The second way is for you to hire someone skilled in this occupation to go to the courthouse to find and purchase copies of the Deed(s) and/or Plat(s) for you. This may be the quickest way but will cost you more. The following companies, among others, can assist you in gathering these documents:

Companies and Individuals able to do title, deed, and easement searches

BUTTE COUNTY

Belle Butte Title Co
713 6th Ave
Belle Fourche, SD 57717
(605) 892-3949

LAWRENCE COUNTY

Black Hills Land Title Co
2011 N Main St
Spearfish, SD 57783
(605) 642-7304

BLACK HILLS LAND TITLE CO

83 Sherman St.
Deadwood, SD 57732
(605) 578-2376

CUSTER COUNTY

Custer Title Co
322 Mt Rushmore Rd
Custer, SD 57730
(605) 673-4838, talk to Joyce

FALL RIVER COUNTY

Fall River Abstract
PO Box 908
Hot Springs, SD 57747
(605) 745-5187, talk to Shelly

MEADE COUNTY

Meade County Title Co
1530 Junction Ave
Sturgis, SD 57785
(605) 347-4402
Toll Free 1-800-732-7694

1. THE CUSTOMER IS URGED TO MAKE EARLY CONTACT WITH THE COMPANY FOR PERMANENT SERVICE.
2. AN AFFIDAVIT OR INSPECTION MUST BE OBTAINED FROM THE AUTHORITY HAVING JURISDICTION BEFORE SERVICE CAN BE PROVIDED.
3. PERMANENT SERVICES MUST BE LOCATED WHERE THE METER WILL BE PROTECTED FROM MECHANICAL INJURY. SHOULD RELOCATION OF A PERMANENT SERVICE BECOME NECESSARY, THE RELOCATION COST WILL BE THE RESPONSIBILITY OF THE CUSTOMER.
4. OVERHEAD PERMANENT SERVICE DROPS SHALL BE SUPPORTED ON COMPANY APPROVED POLE, WALL, OR STRUCTURE. THE MAXIMUM SERVICE DROP LENGTH FROM COMPANY POLE TO THE SERVICE DEPENDS UPON CONDUCTOR SIZE. CONSULT WITH YOUR COMPANY REPRESENTATIVE TO DETERMINE THE MAXIMUM DISTANCE. PERMANENT SERVICE MUST MEET COMPANY STANDARDS.
5. CUSTOMER OWNED METERING EQUIPMENT, SWITCHING DEVICES, CONDUITS, CONDUCTORS, LUMINARIES, ETC., ARE NOT TO BE MOUNTED ON COMPANY POLES.
6. THREE (3) FEET MINIMUM WORKING SPACE REQUIRED BETWEEN ELECTRICAL METER AND ANY OTHER OBSTRUCTION ATTACHED TO THE BUILDING. (SEE NEC REQUIREMENTS)
7. CUSTOMER HAS RESPONSIBILITY TO PROVIDE AND MAINTAIN A THREE (3) FOOT CLEARANCE FROM ALL TREE LIMBS FOR THE ELECTRICAL OVERHEAD SERVICE FROM THE POLE TO THE SERVICE ATTACHMENT ON THE CUSTOMERS BUILDING OR DWELLING.
8. WHEN PRACTICAL, EQUIPMENT OR OTHER OBSTRUCTIONS SHALL MAINTAIN A MINIMUM CLEARANCE OF TEN (10) FEET AWAY FROM A COMPANY POLE. THIS INCLUDES ITEMS SUCH AS TEMPORARY SERVICE PEDESTALS OR POLES, METER PEDESTALS, COMMUNICATION PEDESTAL, PADMOUNT TRANSFORMERS, FENCES, ETC..
9. GROUNDING REQUIREMENTS:
 - A. GROUND WIRE – NO. 6 COPPER MINIMUM – IN SEPARATE CONDUIT NOT IN WITH COMPANY WIRE.
 - B. GROUND RODS -- 8' LONG -- 5/8" GROUND ROD, AS PER CURRENT ISSUE OF N.E.C.
 - C. ALL GROUND RODS TO BE INSTALLED IN UNDISTURBED EARTH.
 - D. ALL GROUND RODS TO BE EMBEDDED BELOW PERMANENT MOISTURE LEVEL PER N.E.C.
10. METERING REQUIREMENTS: (METER FURNISHED BY COMPANY)
 - A. ALL METER HOUSINGS TO BE RING-LESS, NO RING TYPE.
 - B. ANY COMMERCIAL METER HOUSING MUST HAVE BYPASS HANDLE.
 - C. ANY RESIDENTIAL METER HOUSING MUST HAVE HORN TYPE BYPASS.
 - D. ALL UNDER GROUND METER HOUSINGS MUST BE AT LEAST 200 AMP AS PER COMPANY STANDARDS AND INSTALLED LEVEL IN ALL DIRECTIONS.
 - D. ALL PERMANENT OVER HEAD METER HOUSINGS MUST BE AT LEAST 150 AMP AS PER COMPANY STANDARDS AND INSTALLED LEVEL IN ALL DIRECTIONS.
 - F. METER HOUSINGS SHALL TO CONFORM TO ALL COMPANY CRITERIA. (REFER TO SECTION 4, METERING)
 - G. ALL METERS TO BE OUTSIDE OF BUILDINGS – NOT INSIDE.
 - H. METER LOCATIONS SHALL BE DETERMINED BY THE COMPANY REPRESENTATIVE AND MAY VARY DEPENDING ON REAR OR FRONT LOCATION OF DISTRIBUTION FACILITIES.
 - I. IF SELF CONTAINED METER HOUSING IS NOT ATTACHED TO A BUILDING, A SERVICE DISCONNECT WILL BE REQUIRED ON THE LOAD SIDE OR ADJACENT TO THE METER HOUSING. BOTH DISCONNECT AND WIRE ON THE LOAD SIDE WILL BE CUSTOMER OWNED.
 - J. WHEN USING MULTIPLE METER HOUSINGS THE SERVICE ADDRESS SHALL BE CLEARLY MARKED AND SECURELY ATTACHED TO METER SOCKET BY MEANS OF A PERMANENT STAMPED BRASS, ALUMINUM OR STAINLESS STEEL TAG.
11. CONDUIT:
 - A. PVC MINIMUM IS SCHEDULE 40.
 - B. NO LB ELBOWS ON LINE SIDE CONDUIT ALLOWED, ALL CORNERS SHALL BE OF THE SWEEP VARIETY.
 - C. SLIP SLEEVES ARE REQUIRED ON ALL PVC RISERS.
12. CUSTOMER OWNED GUYING, WHEN REQUIRED, TO BE ADEQUATE FOR WIRE SIZE AND SPAN LENGTHS. SEE YOUR COMPANY REPRESENTATIVE FOR RECOMMENDATIONS.

CU BOOK:	REVISION DATE	APPROVED BY:	REQUIREMENTS FOR PERMANENT ELECTRIC SERVICE	METERING STANDARDS DRAWING # 1410-SV1	
METER	6/4/19	LS			
DRAWN BY:	REVISION NO.	DATE			
AP	9	6/4/19			

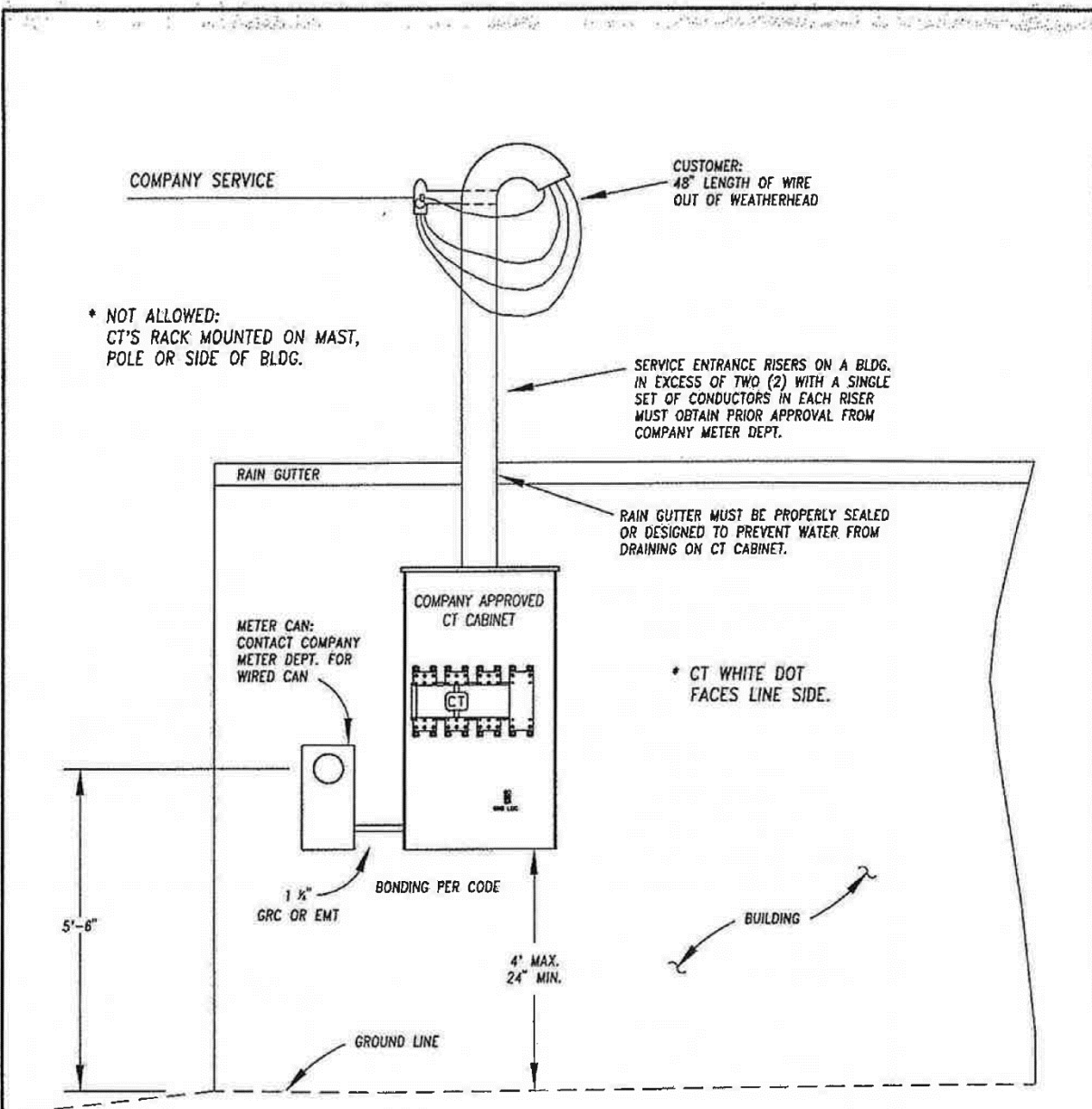

* NOT ALLOWED:
CT'S RACK MOUNTED ON MAST,
POLE OR SIDE OF BLDG.

SERVICE ENTRANCE RISERS ON A BLDG.
IN EXCESS OF TWO (2) WITH A SINGLE
SET OF CONDUCTORS IN EACH RISER
MUST OBTAIN PRIOR APPROVAL FROM
COMPANY METER DEPT.

RAIN GUTTER MUST BE PROPERLY SEALED
OR DESIGNED TO PREVENT WATER FROM
DRAINING ON CT CABINET.

* CT WHITE DOT
FACES LINE SIDE.

5'-6"

1 1/2"
GRC OR EMT

BONDING PER CODE

4' MAX.
24" MIN.

GROUND LINE

BUILDING

NOTES:

- A) INSTRUMENT METERING WILL BE REQUIRED ON:
 - 1Ø LOADS ABOVE 400 AMPS AND
 - 3Ø LOADS ABOVE 200 AMPS.
 - 480 VOLT SERVICES
 DUAL COMPARTMENT METER HOUSING
MUST BE USED ON 480V SERVICES
- B) SERVICE ENTRANCE CONDUCTORS SHALL NOT
PASS THROUGH ANY OTHER ENCLOSURE
PRIOR TO CT CABINET.
- C) CONDUCTORS SHALL NOT PASS IN FRONT
OF BUSS OR CT.
- D) TOP LUGS IN CT CABINET
SHALL BE LINE SIDE.

C.T. CABINETS:

- * MUST BE APPROVED BY THE COMPANY
- * NEMA 3R RATED
- * UL LISTED C.T. CABINET
- * FURNISHED WITH FACTORY LUGS FOR PHASE AND NEUTRAL
CONDUCTORS AND PROVISIONED FOR USE WITH STANDARD
BAR-TYPE C.T.s
- * RATED AND/OR INSTALLED TO MEET APPROPRIATE SHORT
CIRCUIT CURRENT RATING.
(SEE NEC® AND AUTHORITY HAVING JURISDICTION)
- * CABINET USE FOR SERVICES UP TO 800 AMPS.
PRIOR APPROVAL FROM COMPANY METER DEPT.
MUST BE OBTAINED FOR USE OVER 800 AMPS.

DSGN.	M.C.
DR.	DH
APPROVED BY	DATE

METERING STANDARD

**INSTRUMENT METERING
OVERHEAD SERVICES**



REV DATE 12/14/11

REV NO. 1

DRAWING NUMBER

1440-TR1

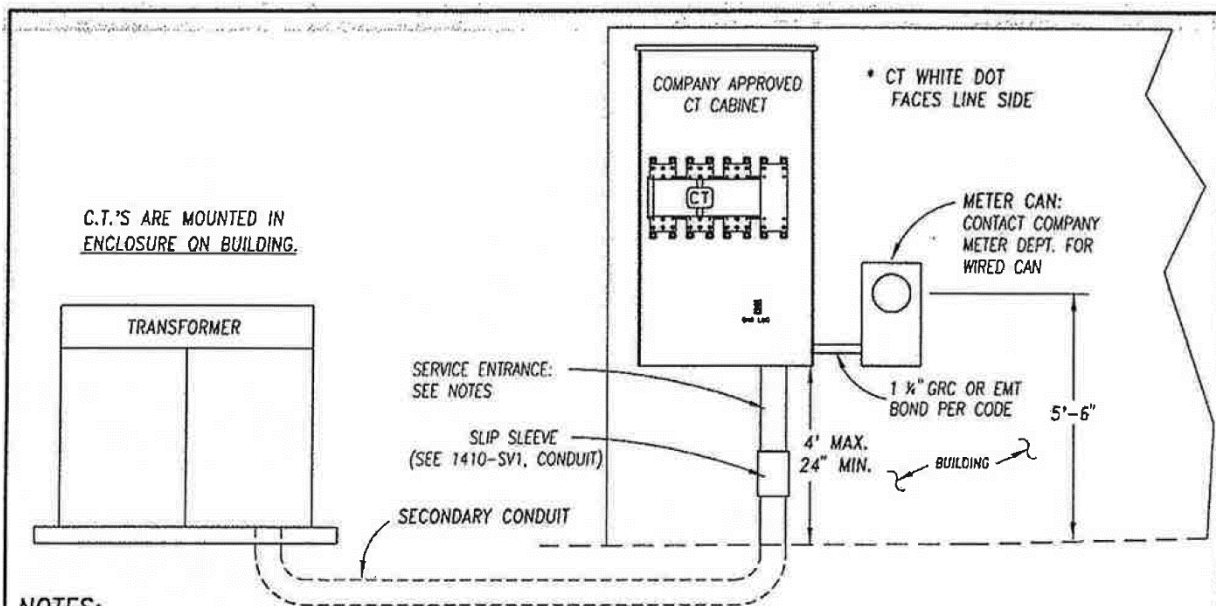

NOTES:

- A) INSTRUMENT METERING WILL BE REQUIRED ON:
 - *1Ø LOADS ABOVE 400 AMPS
 - *3Ø LOADS ABOVE 200 AMPS
 - *480 VOLT SERVICES
 DUAL COMPARTMENT METER HOUSING MUST BE USED ON 480V SERVICES
- B) SERVICE ENTRANCE RISERS IN EXCESS OF TWO (2) WITH A SINGLE SET OF CONDUCTORS IN EACH RISER MUST OBTAIN PRIOR APPROVAL FROM COMPANY METER DEPT.
- C) SERVICE ENTRANCE CONDUCTORS SHALL NOT PASS THRU ANY OTHER ENCLOSURE PRIOR TO CT CABINET
- D) CONDUCTORS SHALL NOT PASS IN FRONT OF BUSS OR CT.
- E) TOP LUGS IN CT CABINET SHALL BE LINE SIDE.

C.T. CABINETS:

- * MUST BE APPROVED BY COMPANY
- * NEMA 3R RATED
- * UL LISTED C.T. CABINET
- * FURNISHED WITH FACTORY LUGS FOR PHASE AND NEUTRAL CONDUCTORS AND PROVISIONED FOR USE WITH STANDARD BAR-TYPE C.T.s
- * RATED AND/OR INSTALLED TO MEET APPROPRIATE SHORT CIRCUIT CURRENT RATING. (SEE NEC AND AUTHORITY HAVING JURISDICTION)
- * CABINET USE FOR SERVICES UP TO 800 AMPS. PRIOR APPROVAL FROM COMPANY METER DEPT. MUST BE OBTAINED FOR USE OVER 800 AMPS.

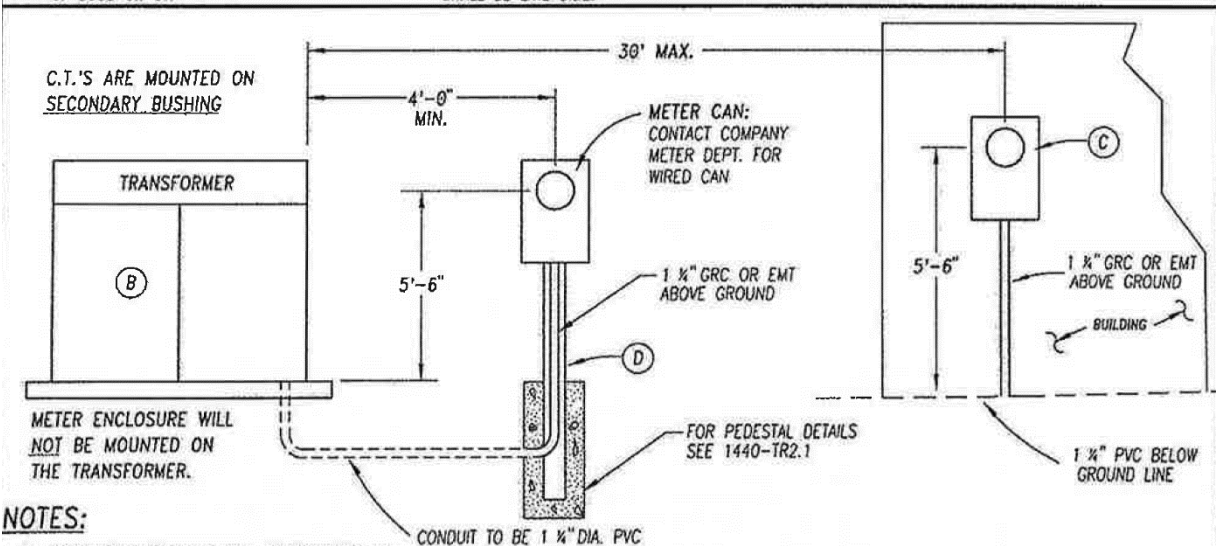

NOTES:

- A) INSTRUMENT METERING WILL BE REQUIRED ON:
 - *1Ø LOADS ABOVE 400 AMPS
 - *3Ø LOADS ABOVE 200 AMPS
 - *480 VOLT SERVICES
 DUAL COMPARTMENT METER HOUSING MUST BE USED ON 480V SERVICES
- B) TRANSFORMER MUST BE FOR SINGLE CUSTOMER SERVICE ONLY (DEDICATED TRANSFORMER)
- C) THE PREFERRED METER LOCATION IS ON THE BUILDING LOCATION MUST BE WITHIN 30' CONDUIT RUN. FOR DISTANCES GREATER THAN 30' A PEDESTAL MUST BE USED.
- D) METER PEDESTAL TO BE SUPPLIED BY THE CUSTOMER.

DSGN.	D.G.
DR.	JH/DCL
APPROVED BY	DATE

METERING STANDARD

INSTRUMENT METERING UNDERGROUND SERVICES



REV DATE	REV
12/14/11	1
DRAWING NUMBER	
1440-TR2	

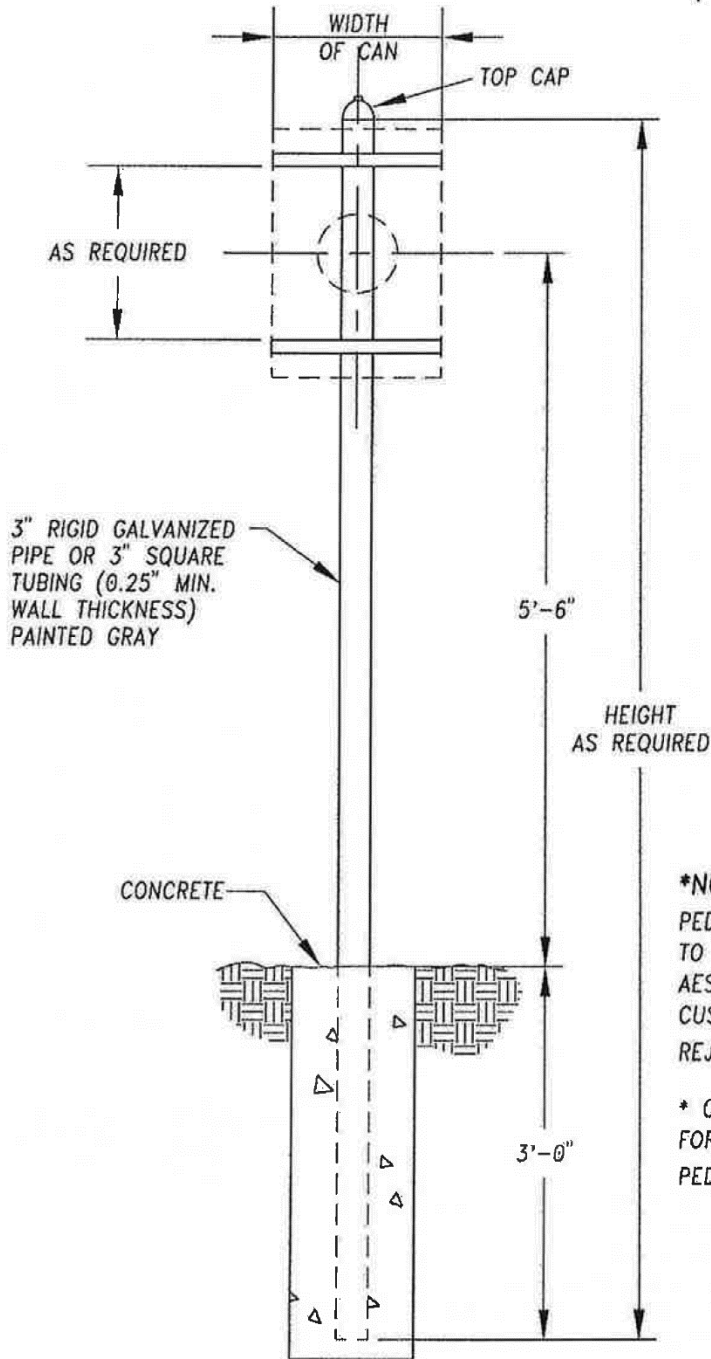
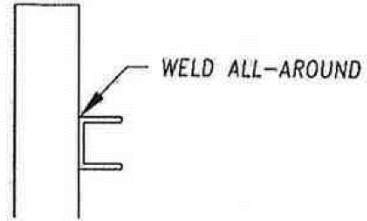
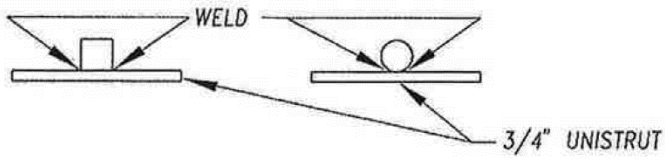

***NOTE:**
 PEDESTALS THAT ARE NOT MADE TO SPECIFICATION, AND ARE NOT AESTHETICALLY APPEALING TO THE CUSTOMER OR UTILITY, MAY BE REJECTED AND REQUIRE REPLACEMENT.

* CONTACT LOCAL UTILITY REPRESENTATIVE FOR USE OF MANUFACTURED INST. METER PEDESTALS. SEE 1440-TR2.2

DSGN.	P.K.
DR.	CEI
APPROVED BY	DATE

DISTRIBUTION STANDARD
INSTRUMENT METERING PEDESTAL FOR PERMANENT UNDERGROUND SERVICES
 BLACK HILLS CORP.



REV DATE	REV NO.
11/99	8
DRAWING NUMBER	
1440-TR2.1	

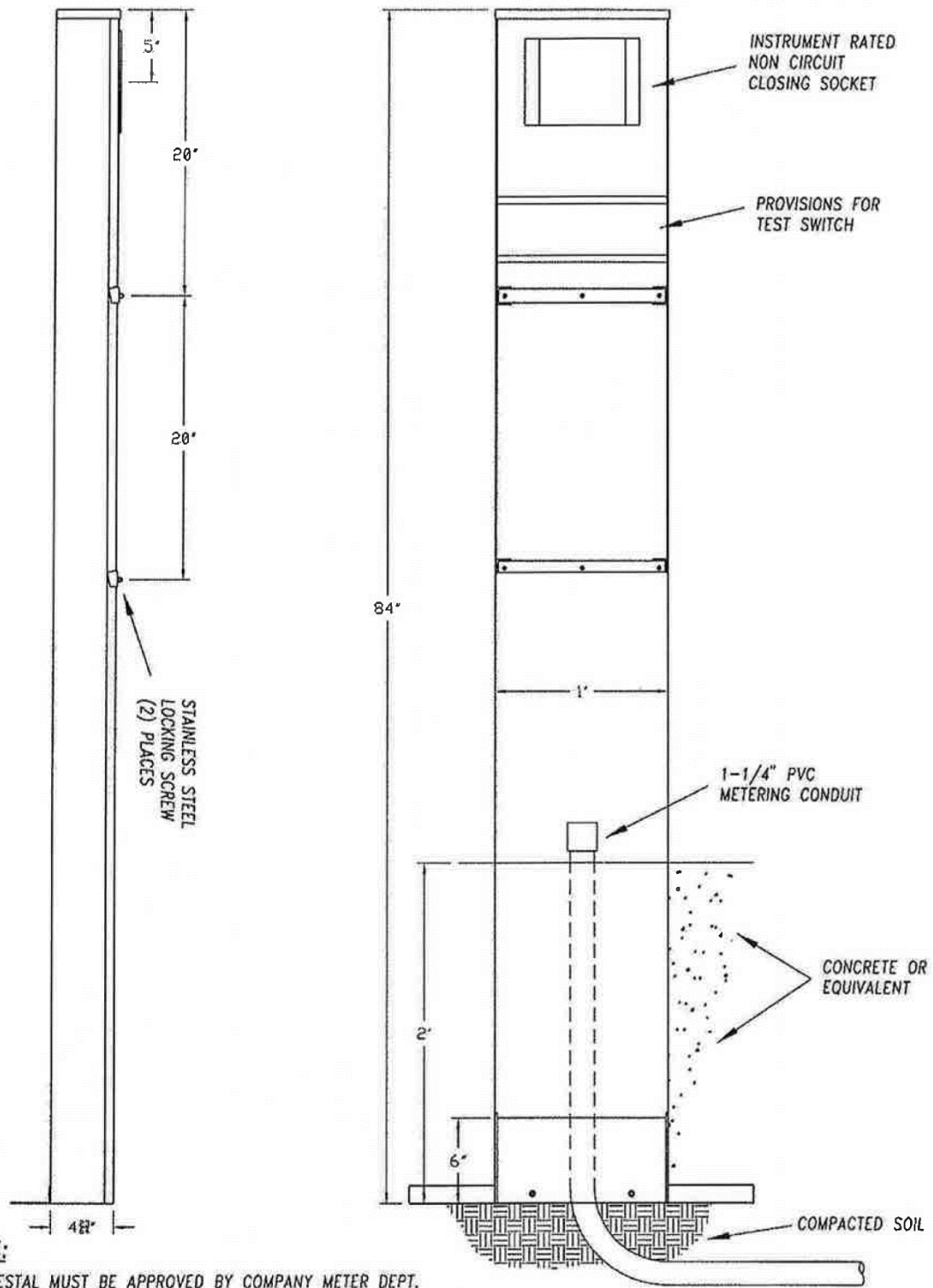

NOTES:

- 1) PEDESTAL MUST BE APPROVED BY COMPANY METER DEPT. PRIOR TO INSTALLATION.
- 2) UNIT RATING 20A, 600VAC
- 3) ALL COMPARTMENTS MUST BE LOCKABLE.
- 4) UNIT CONSTRUCTION: GALVANIZED STEEL, PAINTED GRAY.
- 5) THE ELECTRIC METER SHALL FACE AWAY FROM ANY STRUCTURE.
- 6) THE PEDESTAL SHALL BE INSTALLED TO MAINTAIN VERTICAL ALIGNMENT THROUGHOUT THE LIFE OF THE INSTALLATION.

DSGN.	K.M.
DR.	DH
APPROVED BY	DATE

DISTRIBUTION STANDARD
MANUFACTURED INSTRUMENT METERING PEDISTAL
FOR PERMANENT UNDERGROUND SERVICE
 BLACK HILLS CORP.



REV. DATE	REV. #
DRAWING NO.	
1440-TR2.2	

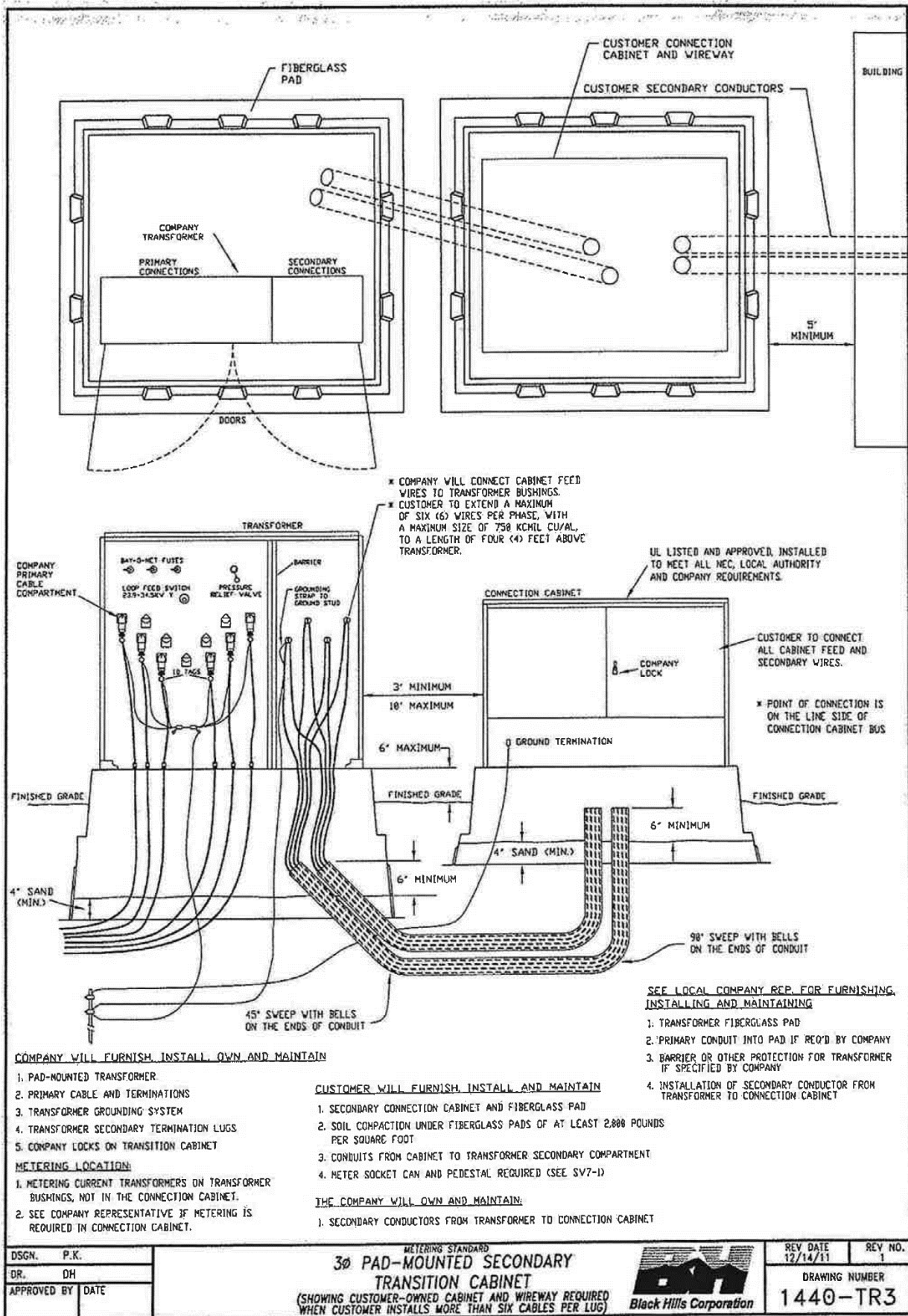

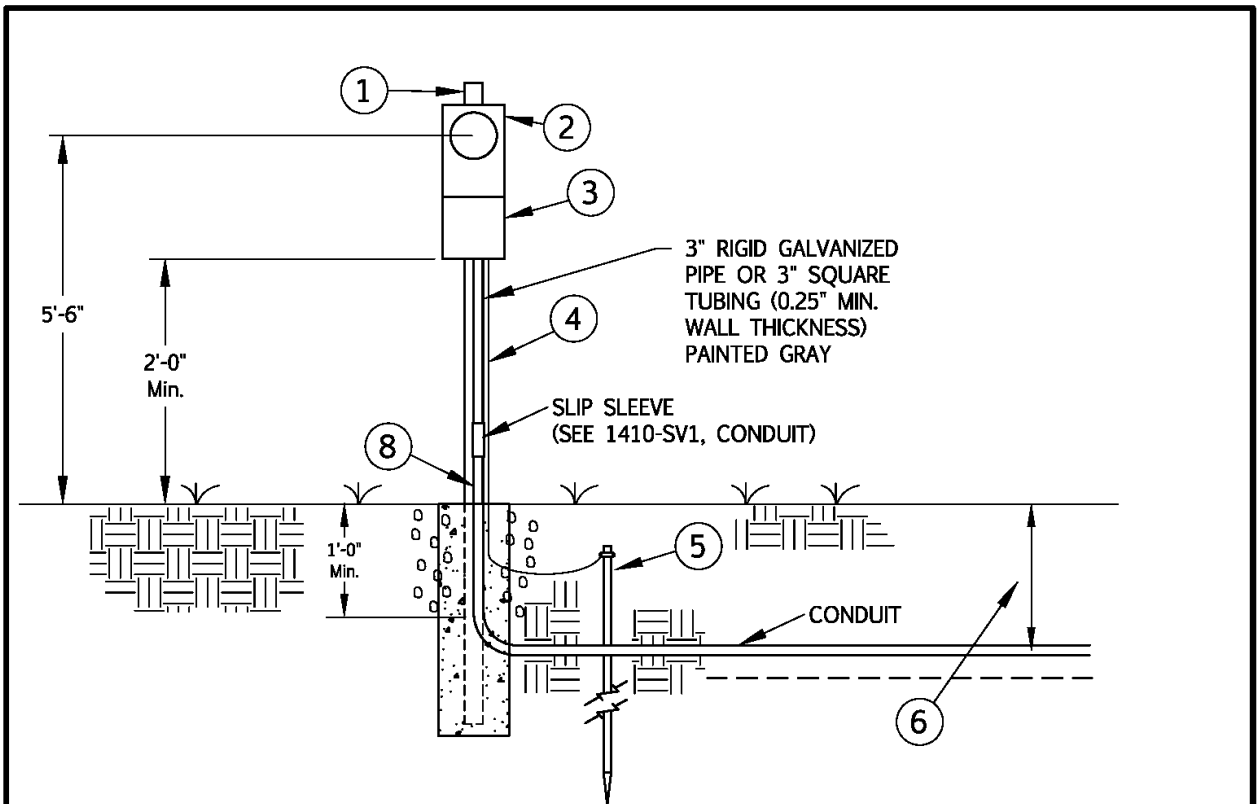

NOTES:

1. FOR PEDESTAL DETAIL SEE: 1410-SV5.1, FOR U.L. APPROVED, FACTORY MADE METER/PEDESTAL CABINET WITH SERVICE DISCONNECT SEE 1410-SV6. OTHER DESIGNS MUST BE PRE-APPROVED BY A COMPANY REPRESENTATIVE.
2. METER CAN MUST BE COMPANY APPROVED RINGLESS TYPE AND INSTALLED LEVEL IN ALL DIRECTIONS. ALL COMMERCIAL METER CAN INSTALLATIONS MUST HAVE A MECHANICAL BYPASS - RESIDENTIAL, A HORNED BYPASS.
3. CUSTOMER DISCONNECT EQUIPMENT - WEATHER TIGHT - SELF CONTAINED - SWITCH BOX MUST BE COVERED WHEN INSPECTED.
 - A) SINGLE PHASE - MINIMUM CAPACITY 30 AMPERES. TO MAXIMUM CAPACITY OF 400 AMPERES.
 - B) THREE PHASE SERVICES OVER 200 AMPERES, MUST BE INSTRUMENT METERED.
 - C) ALL 480 VOLT SERVICES, MUST BE INSTRUMENT RATED.
4. GROUND WIRE - NO. 6 COPPER MINIMUM.
5. GROUND ROD -- 8' LONG -- 5/8" GROUND ROD. A BUTT WRAPPED COPPER GROUND WIRE IS ALSO ACCEPTABLE.
6. CONTACT LOCAL UTILITY FOR TRENCHING SPECIFICATIONS AND RESPONSIBILITIES.
7. A PERMIT FOR PERMANENT SERVICE OR A WIRING AFFIDAVIT APPROVING THE SERVICE FOR CONNECTION MUST BE OBTAINED BEFORE SERVICE CAN BE PROVIDED.
8. SERVICE ENTRANCE - CUSTOMER WILL PROVIDE:
 - A) COMMERCIAL - FROM A PAD MOUNT TRANSFORMER TO CUSTOMERS SERVICE ENTRANCE;
 - * ALL SECONDARY CONDUCTORS
 - * ALL PVC CONDUIT (3" SCHEDULE 40 MINIMUM SIZE) REQUIRED.
 - B) COMMERCIAL - FROM OVERHEAD TRANSFORMERS:
 - * CONTACT LOCAL COMPANY REPRESENTATIVE ABOUT OWNERSHIP AND INSTALLATION.
 - C) RESIDENTIAL FROM OVERHEAD OR PADMOUNT TRANSFORMER TO CUSTOMERS SERVICE ENTRANCE:
 - * COMPANY WILL PROVIDE ALL LINE SIDE CONDUCTORS, AND POLE CONDUIT -
 - * ALL OTHER CONDUIT SHALL BE PROVIDED BY CUSTOMER.
9. UNDERGROUND SERVICE LINE MUST BE COVERED OR BACK FILLED BEFORE SERVICE MAY BE ENERGIZED.
10. SEE 1410-SV1 FOR ANY OTHER REQUIREMENTS.

CUI BOOK:	REVISION DATE	APPROVED BY:	SELF CONTAINED UNDERGROUND PERMANENT SERVICE - STEEL POST	METERING STANDARDS DRAWING # 1410-SV5	
METER	6/4/19	LS			
DRAWN BY:	REVISION NO.	DATE			
AP	8	6/4/19			

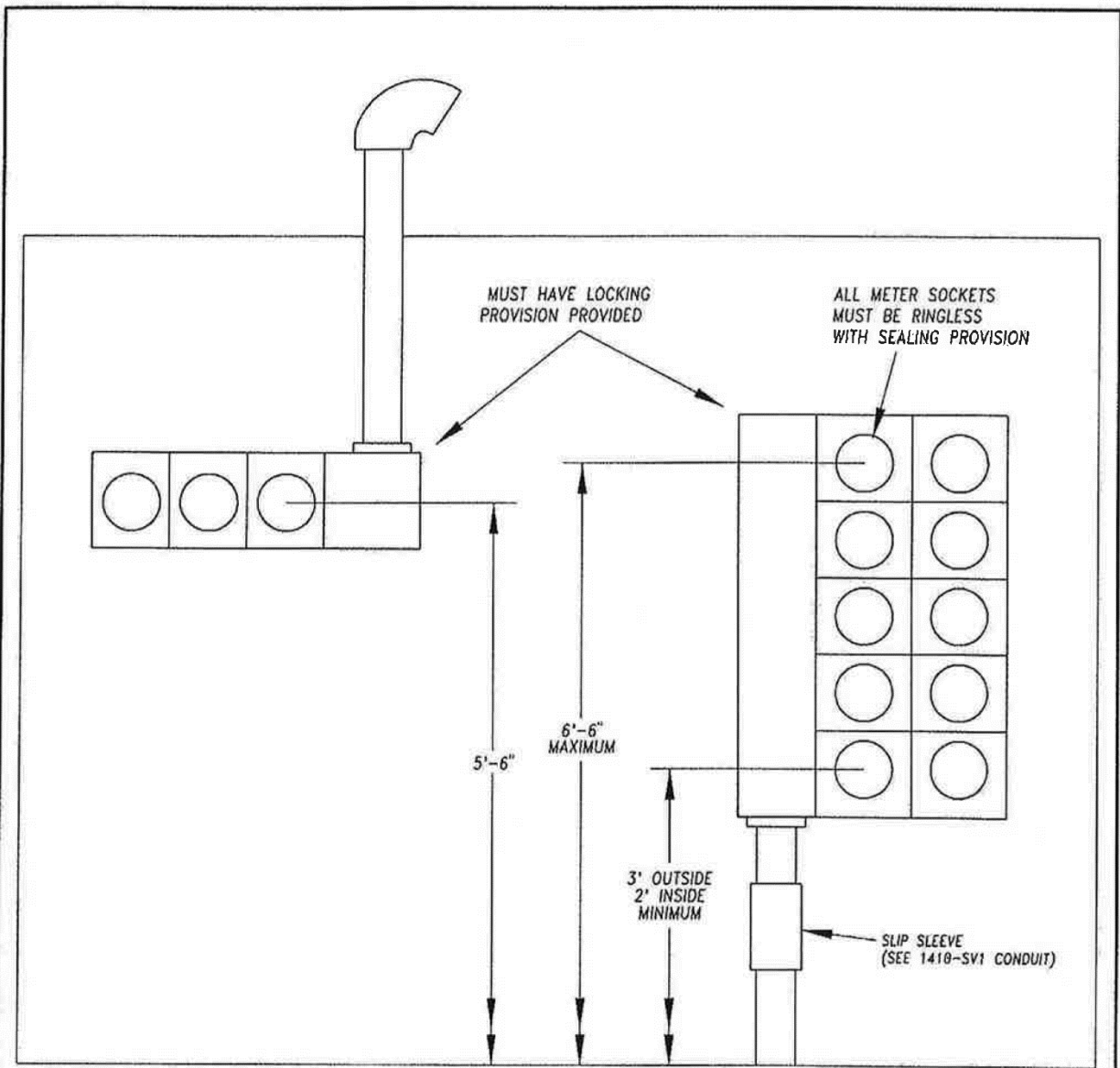

* METER MODULES OF ALL TYPES ARE TO BE MOUNTED NO LOWER THAN 24 INCHES CENTERLINE TO THE FIRST METER FROM THE GROUND AND NO HIGHER THAN 78 INCHES CENTERLINE TO THE TOP METER FROM THE GROUND. STANDARD SINGLE METER HEIGHT IS 66 INCHES FROM THE GROUND.

NOTE:

- * LEVER OPERATED BYPASS REQUIRED ON ALL COMMERCIAL SOCKETS.
- * HORNED BYPASS REQUIRED ON ALL RESIDENTIAL SOCKETS.
- * PERMANENTLY AFFIXED IDENTIFICATION TAGS ARE REQUIRED (SEE 1410-SV1)
- * UL APPROVED MANUFACTURED METER MODULES INSTALLED BY CUSTOMER PER NEC, LOCAL AUTHORITY AND COMPANY RULES.
- * ATTACHED CT COMPARTMENTS OR ANY SWITCHGEAR / CT COMPARTMENTS MUST OBTAIN PRE-APPROVAL FROM THE COMPANY METER DEPARTMENT.

DSGN.	D.G.
DR.	J.H./D.C.L.
APPROVED BY	DATE

DISTRIBUTION STANDARD
**GANG METER MODULES AND
 METER PEDESTALS**
 BLACK HILLS CORP.



REV. DATE	REV. NO.
11/82	4
DRAWING NO.	
1410-SV8	

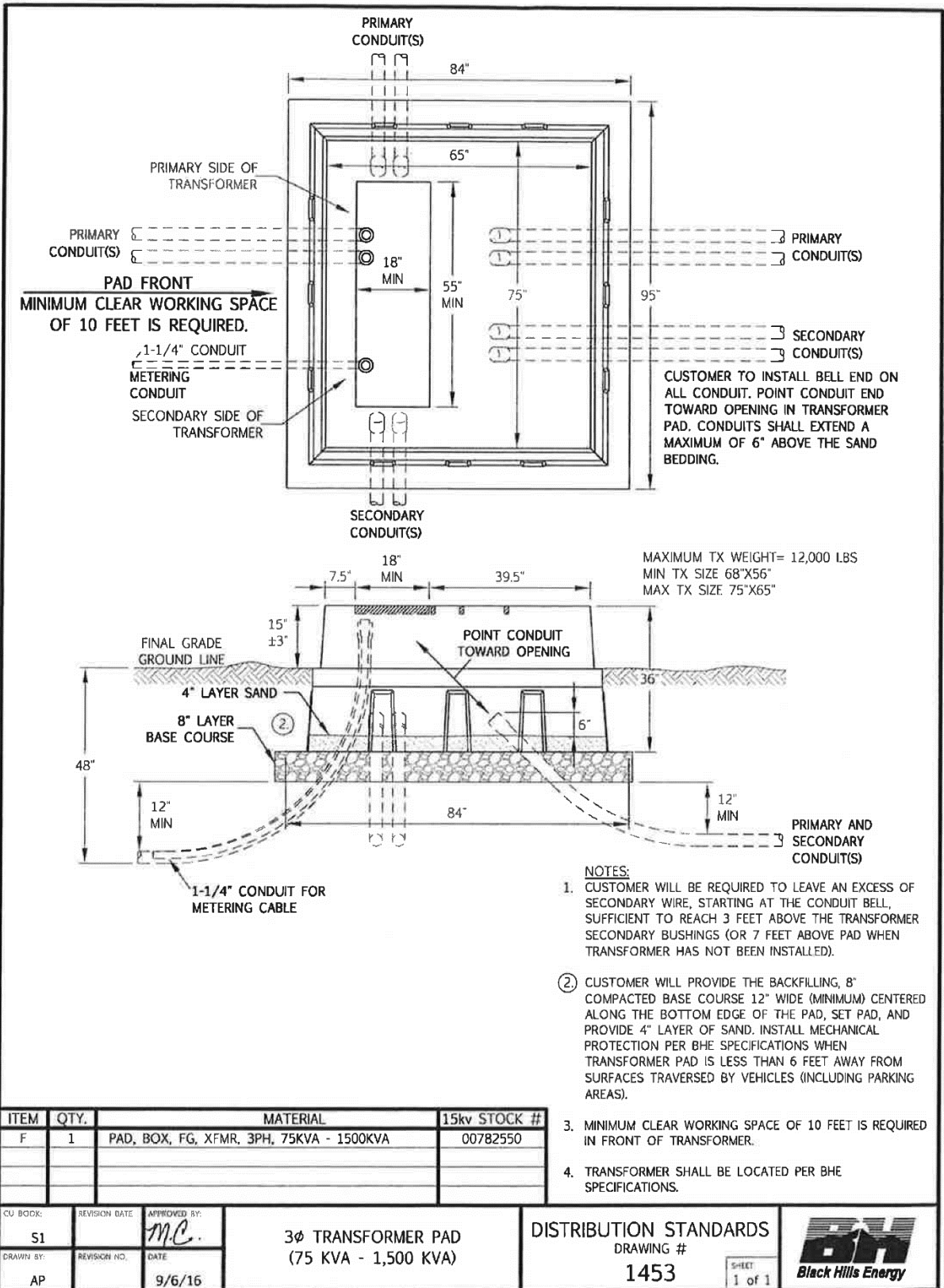

GENERAL:

- 1) PAD MOUNT TRANSFORMERS SHALL BE LOCATED IN AN AREA ACCESSIBLE TO LINE TRUCKS FOR EASY INSTALLATION AND REMOVAL.
- 2) PAD MOUNT TRANSFORMERS SHALL BE LOCATED IN AN AREA NOT SUBJECTED TO FLOODING.
- 3) PADS FOR TRANSFORMERS SHALL BE PROTECTED AGAINST LANDSLIDES, DRAINAGE WASH OR DRIFTING SAND, ETC. THE INSTALLATION OF RETAINING WALLS OF SUFFICIENT STRENGTH AND SUITABLE CONSTRUCTION TO PROVIDE ADEQUATE PROTECTION SHALL BE THE RESPONSIBILITY OF THE CUSTOMER.
- 4) PADS FOR TRANSFORMERS SHALL BE INSTALLED AND MAINTAINED LEVEL.
- 5) ANY PROTECTIVE OR DECORATIVE FENCING OR ENCLOSURE TO BE BUILT AROUND A PAD MOUNTED TRANSFORMER MUST BE APPROVED BY CUSTOMER SERVICES AND ENGINEERING PRIOR TO INSTALLATION.

BASIC HORIZONTAL CLEARANCES: (FIGURE 1)

THE FOLLOWING HORIZONTAL CLEARANCES BETWEEN PAD MOUNTED TRANSFORMERS AND ADJACENT STRUCTURES ARE REQUIRED:

- 1) TEN FEET MINIMUM FROM COMBUSTIBLE SURFACES. CUSTOMER SHALL PROVIDE NON-COMBUSTIBLE SURFACES OR FIRE-RESISTANT BARRIERS IF CLEARANCE IS LESS THAN 10'.
- 2) TWO FEET MINIMUM FROM A NON-COMBUSTIBLE SURFACE ON ANY SIDE AND AT LEAST 10' CLEAR WORKING SPACE ON THE FRONT SIDE OF THE TRANSFORMER.
- 3) OVERHANGS (COMBUSTIBLE)
 - a) IF AN OVERHANG OF COMBUSTIBLE MATERIAL CLEARS THE TOP OF OIL-FILLED PAD MOUNTED TRANSFORMERS BY A MINIMUM OF 20' VERTICALLY, THE REQUIRED DISTANCE SHALL BE MEASURED FROM THE BUILDING WALL.
 - b) IF AN OVERHANG OF COMBUSTIBLE MATERIAL CLEARS THE TOP OF OIL-FILLED PAD MOUNTED TRANSFORMERS LESS THAN 20' VERTICALLY THE REQUIRED CLEARANCE SHALL BE MEASURED FROM THE FARTHEST PROJECTION OF THE OVERHANG.

CLEARANCE FROM AIR INTAKE, WINDOWS, DOOR AND FIRE ESCAPES: (FIGURE 2)

- 1) **DOORS:** A PAD MOUNT TRANSFORMER SHALL NOT BE PLACED WITHIN A ZONE EXTENDING 20' OUT FROM AND 10' TO EITHER SIDE OF A DOOR.
- 2) **WINDOWS:** A PAD MOUNT TRANSFORMER SHALL NOT BE PLACED WITHIN A ZONE EXTENDING 10' OUT OR 8' EITHER SIDE OF A WINDOW ON THE 1st FLOOR. THE TRANSFORMER SHALL NOT BE ANY CLOSER THAN 5' FROM ANY PART OF A SECOND STORY WINDOW, NOR DIRECTLY BELOW AN OPERATING WINDOW.
- 3) **AIR INTAKES:** A PAD MOUNT TRANSFORMER SHALL NOT BE PLACED WITHIN A ZONE EXTENDING 10' OUT FROM AND 10' TO EITHER SIDE OF AN AIR INTAKE. IF THE AIR INTAKE ABOVE TRANSFORMER, THE TRANSFORMER SHOULD BE 25' FROM THE OPENING.
- 4) **FIRE ESCAPES:** A PAD MOUNT TRANSFORMER SHALL NOT BE PLACED WITHIN A ZONE EXTENDING 20' OUT FROM AND 20' TO EITHER SIDE OF A FIRE ESCAPE.

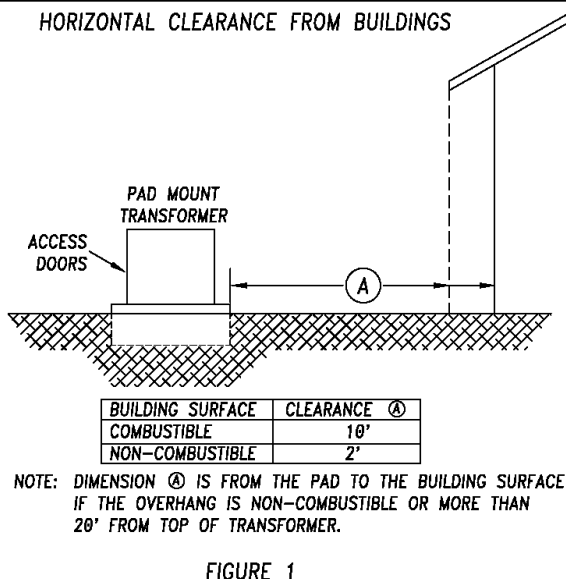

FIGURE 1

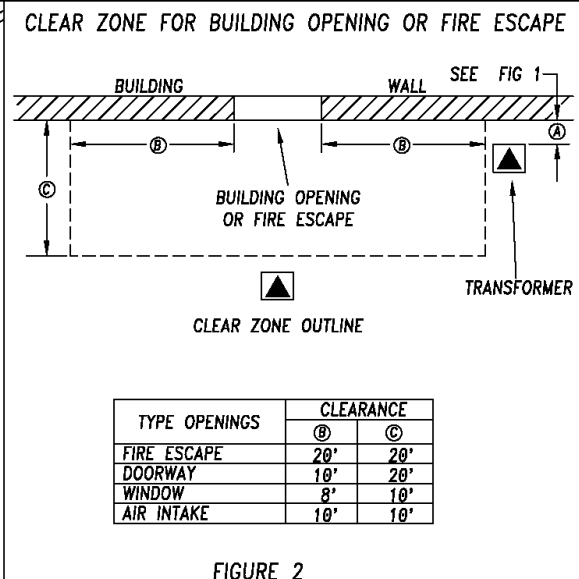

FIGURE 2

DSGN. JS	DISTRIBUTION STANDARD	REV. DATE 9/27/18	REV. NO. 3
DR. AP	PAD-MOUNT TRANSFORMER LOCATIONS AND CLEARANCES	DRAWING NO. PT 1	SHEET 1
APPROVED BY		DATE	
BLACK HILLS ENERGY			

APPLICATION:

IF PAD MOUNTED EQUIPMENT MUST BE LOCATED IN PAVED OR TRAVELED AREAS, OR ADJACENT TO SUCH AREAS WITH THE POSSIBILITY OF DAMAGE FROM VEHICLES, PHYSICAL PROTECTION ACCEPTABLE TO BLACK HILLS POWER AND LIGHT COMPANY MUST BE PROVIDED AND MAINTAINED BY THE CUSTOMER. BLACK HILLS POWER AND LIGHT COMPANY WILL DETERMINE WHEN SUCH PROTECTION IS NECESSARY.

MATERIAL:

GALVANIZED 4" STANDARD PIPE AND END CAP IS THE PREFERRED METHOD OF POST FABRICATION. A SMOOTH CONCRETE DOME IS PERMITTED IN PLACE OF THE END CAP. WHEN A CONCRETE DOME IS USED, THE PIPE END MUST BE FREE OF SHARP EDGES. THE 5" DIAMETER SECTION FOR INSTALLING REMOVABLE POSTS MUST ALSO BE GALVANIZED.

LOCATION:

- 1) LOCATE BARRIER POST SO THEY DO NOT INTERFERE WITH THE OPENING OF EQUIPMENT DOORS. USE REMOVABLE BARRIER POSTS AS FOLLOWS:
 - a) ON DOOR SIDE(S) OF EQUIPMENT WHERE POSTS COULD INTERFERE WITH OPERATION OF LIVE LINE TOOLS.
 - b) WHERE THE USE OF FIXED POSTS WOULD OBSTRUCT ACCESS FOR INSTALLATION OR REPLACEMENT OF EQUIPMENT.
- 2) DIMENSIONS FOR LOCATION OF POSTS WITH RESPECT TO EQUIPMENT PAD ARE DETERMINED AS FOLLOWS: (SEE FIGURE 1)
 - a) DETERMINE THE MOST PRACTICABLE DISTANCE "B" (FOR EACH SIDE) THAT POSTS CAN BE LOCATED FROM THE EDGE OF THE PAD.
 - b) DIMENSION "A" (FOR EACH SIDE) MUST BE LESS THAN OR EQUAL TO 2 TIMES "B" MINUS 6 INCHES BUT SHOULD NOT EXCEED 42 INCHES.
 - c) PLACE THE FIRST POST AT THE INTERSECTION OF PROJECTED CENTERLINES, (POINT X).
 - d) PLACE ONE POST DISTANCE "A" FROM POINT "X" ALONG EACH SIDE TO PROTECT CORNER.
 - e) CONTINUE TO PLACE POSTS DISTANCE "A" APART ALONG SIDES TO BE PROTECTED.
 - f) TO PROTECT ONE SIDE ONLY, PROCEED AS IN "a" AND "b" ABOVE, PLACE FIRST POST DISTANCE "B" FROM EDGE OF PAD AT EACH POINT WHERE PROTECTION IS REQUIRED THEN PROCEED AS IN "e" ABOVE.
 - g) TO PROTECT CORNER ONLY, PROCEED AS IN "a" THROUGH "d" ABOVE.

NOTES:

- 1) A BUILDING WILL FURNISH PROTECTION PROVIDED IT IS LOCATED AT A POINT WHERE A POST WOULD NORMALLY BE REQUIRED.
- 2) SQUARE FACED STREET CURBING PARALLEL TO NORMAL TRAFFIC FLOW CAN BE CONSIDERED SUITABLE PROTECTION IF THE PAD-MOUNT EQUIPMENT IS LOCATED A MINIMUM OF 6 FEET BEHIND THE CURBING.

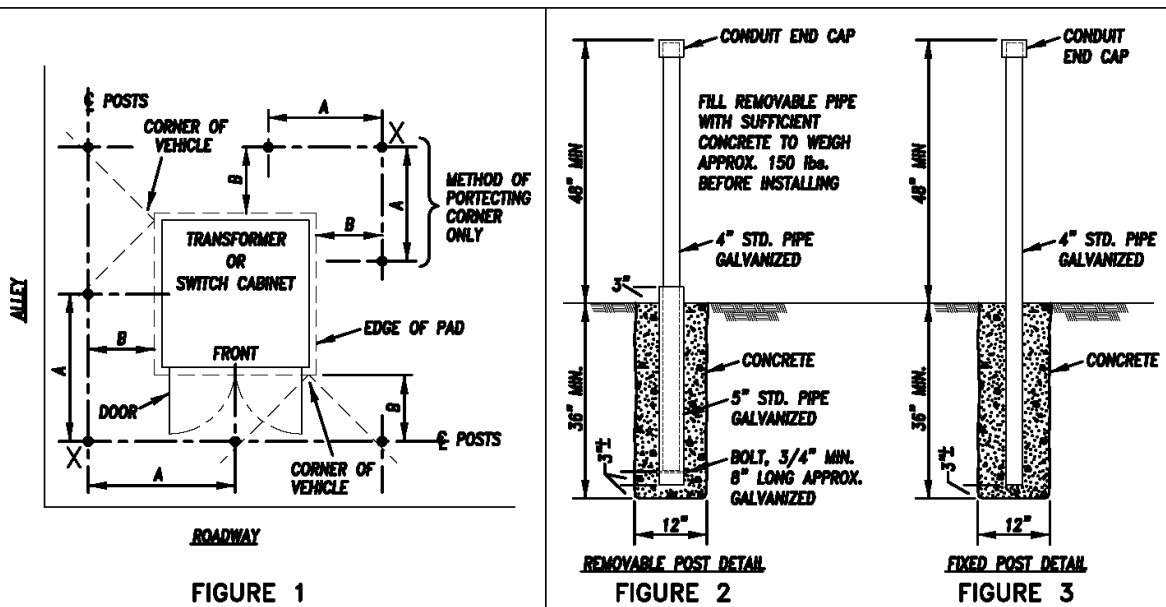

<table border="1"> <tr> <td>DSGN.</td> <td>R.D.</td> </tr> <tr> <td>DR.</td> <td>JM/D.C.L.</td> </tr> <tr> <td>APPROVED BY</td> <td>DATE</td> </tr> </table>	DSGN.	R.D.	DR.	JM/D.C.L.	APPROVED BY	DATE	DISTRIBUTION STANDARD MECHANICAL PROTECTION FOR PAD-MOUNTED EQUIPMENT BLACK HILLS POWER	<table border="1"> <tr> <td>REV. DATE</td> <td>REV. NO.</td> </tr> <tr> <td>4/1/87</td> <td>1</td> </tr> <tr> <td>DRAWING NO.</td> <td>SHEET</td> </tr> <tr> <td>PT 2</td> <td>1</td> </tr> </table>	REV. DATE	REV. NO.	4/1/87	1	DRAWING NO.	SHEET	PT 2	1
DSGN.	R.D.															
DR.	JM/D.C.L.															
APPROVED BY	DATE															
REV. DATE	REV. NO.															
4/1/87	1															
DRAWING NO.	SHEET															
PT 2	1															

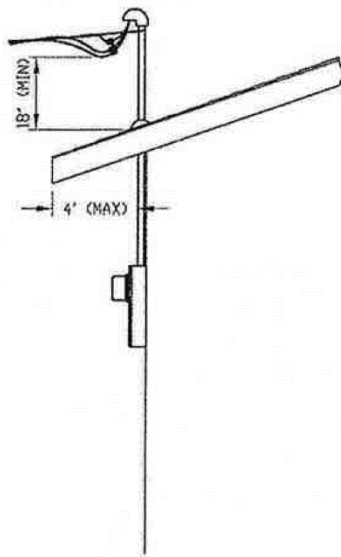
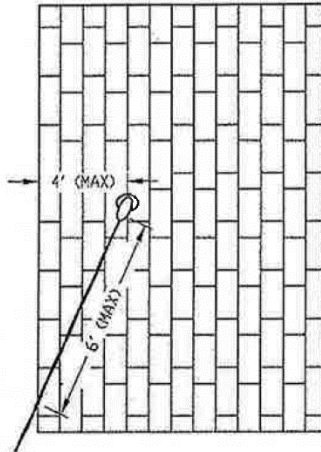

*NOTE: ATTACHMENT POINT OF 48" OR HIGHER, MAST SHALL BE SUPPORTED BY BRACES OR GUYS

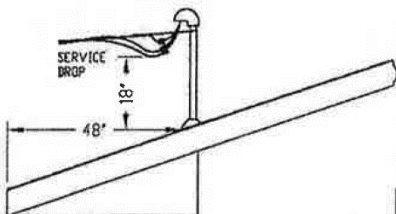
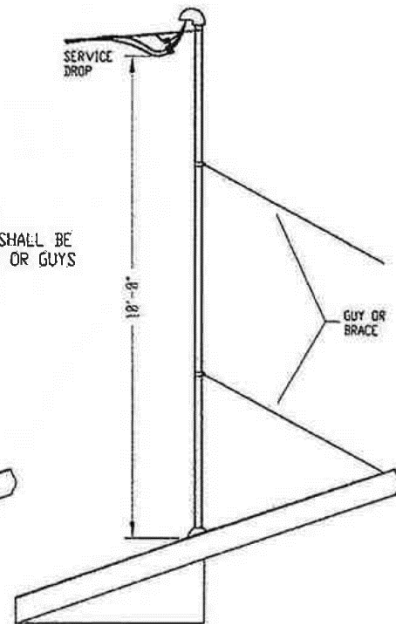

300 VOLTS OR LESS, 18 INCH
MINIMUM CLEARANCE IS PERMITTED
IF CONDUCTORS PASS OVER NOT MORE
THAN 48 INCHES OF ROOF OVERHANG

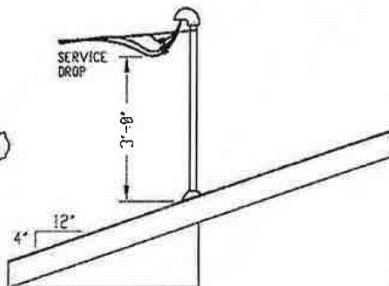

300 VOLTS OR LESS, 3 FT.
MINIMUM CLEARANCE IS PERMITTED
IF ROOF SLOPE IS STANDARD 4 TO 12

DSGN.	D.D./M.W.
DR.	K.M./D.C.L.
APPROVED BY	DATE

PERMANENT SERVICE
CLEARANCES OF SERVICE DROPS 600 VOLTS OR LESS
ATTACHED TO BUILDINGS, SIGNS AND OTHER INSTALLATIONS



REV DATE	REV NO.
02/03/12	5
DRAWING NUMBER	
1430-CL1	

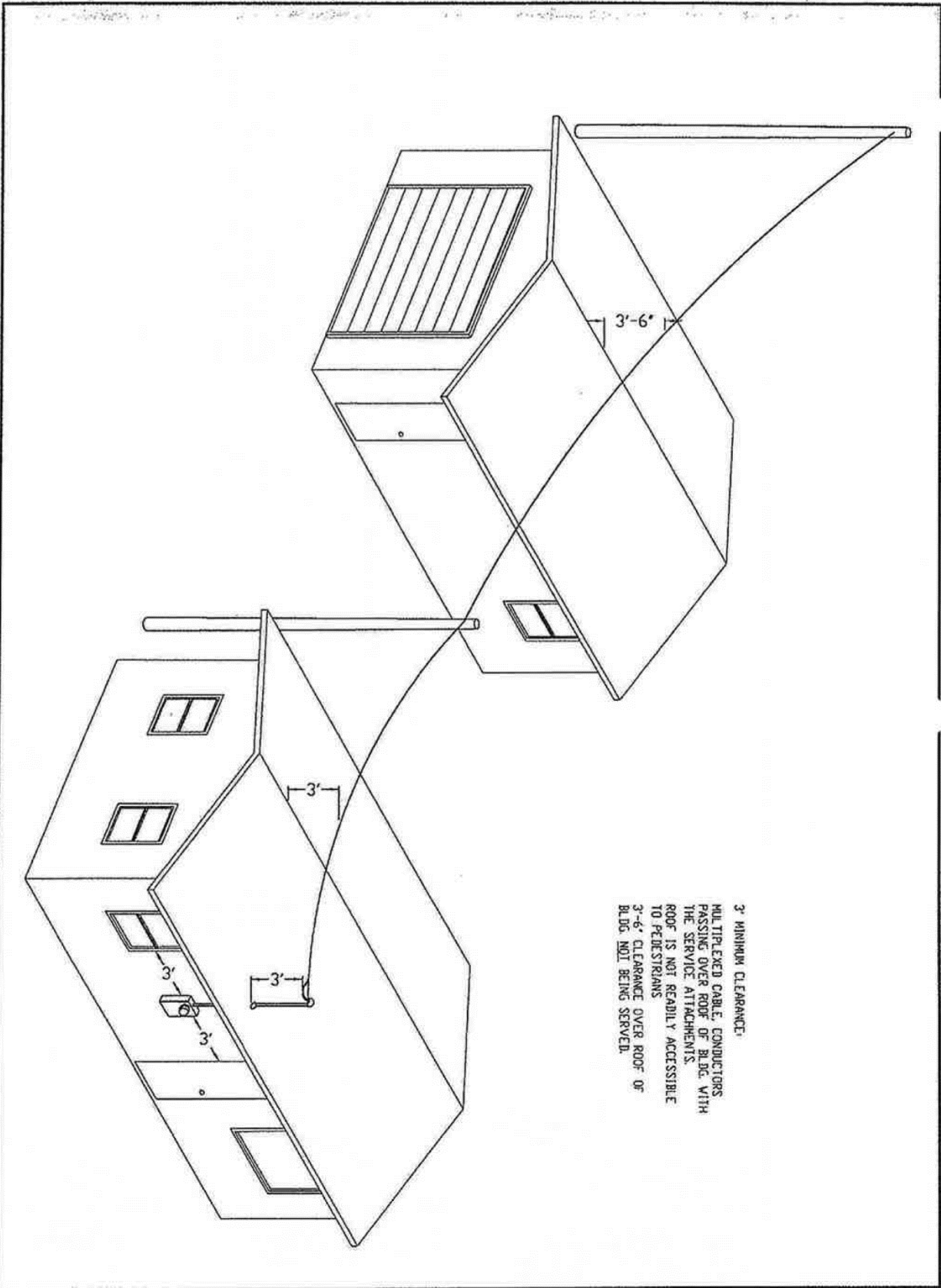

DSGN.	M.G.
DR.	DH
APPROVED BY	DATE

PERMANENT SERVICE

**CLEARANCES OF SERVICE DROPS 600 VOLTS OR LESS
 ATTACHED TO BUILDINGS, SIGNS AND OTHER INSTALLATIONS**



REV DATE	REV NO.
DRAWING NUMBER	
1430-CL2	

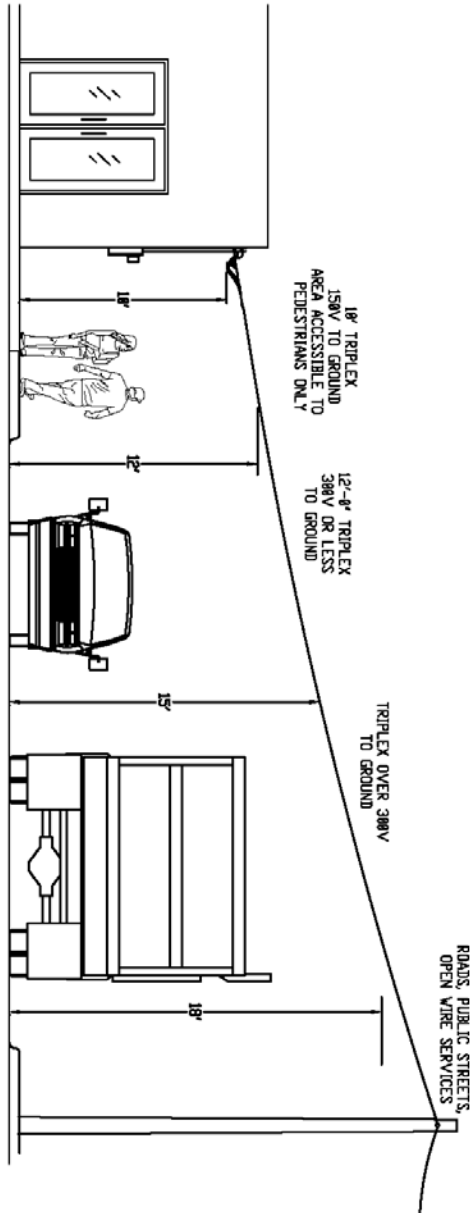

- MINIMUM CLEARANCES**
- 18 FEET - ABOVE FINISHED GRADE, SIDEWALKS OR FROM ANY PLATFORM OR PROJECTION FROM WHICH THEY MIGHT BE REACHED) ACCESSIBLE TO PEDESTRIANS ONLY (Ø TO 150V).
 - 12 FEET - OVER RESIDENTIAL PROPERTY AND DRIVEWAYS & THOSE COMMERCIAL AREAS SUCH AS PARKING LOTS AND DRIVE-IN ESTABLISHMENTS NOT SUBJECT TO TRUCK TRAFFIC (Ø TO 300V).
 - 15 FEET - OVER COMMERCIAL AREAS, PARKING LOTS, AGRICULTURAL OR OTHER AREAS SUBJECT TO TRUCK TRAFFIC.
 - 18 FEET - OVER PUBLIC STREETS, ALLEYS, ROADS AND DRIVEWAYS ON OTHER THAN RESIDENTIAL PROPERTY SUBJECT TO TRUCK TRAFFIC.

DSGN.	D.D./M.W.	PERMANENT SERVICE	CLEARANCES OF SERVICE DROPS 600 VOLTS OR LESS ATTACHED TO BUILDINGS, SIGNS AND OTHER INSTALLATIONS	 Black Hills Corporation	REV DATE	REV NO.
DR.	K.M./D.C.L.				5/4/16	6
APPROVED BY	DATE				DRAWING NUMBER	1430-CL3

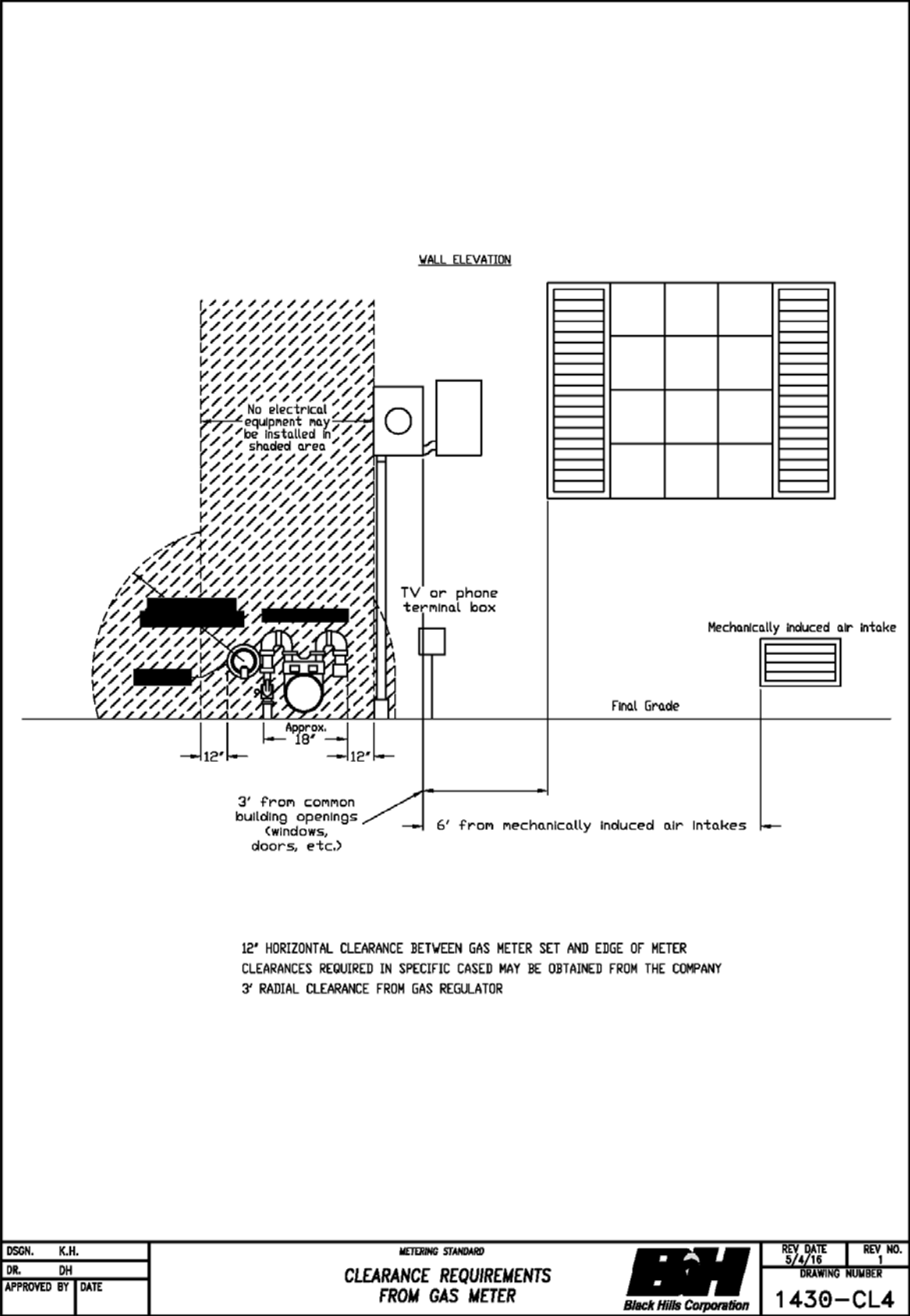

1. The customer is urged to make early contact with the local Company for temporary service.
2. The customer is required to pay a standard fee for temporary service. When special construction is required there will be additional charges.
3. Required affidavits or city inspections must be obtained before service can be provided.
4. In addition to installation and removal charges, the customer will be required to pay a service charge for each metered connection.
5. Temporary services for construction work must be located where the meter will be protected from mechanical injury and, when practical, a location should be selected that would be usable throughout the construction period. Should relocation of a temporary service become necessary the relocation cost will be the responsibility of the Customer.
6. Overhead temporary service drops shall be supported on a Company approved pole or timber and shall be furnished and installed by the Customer. The maximum service drop length from a Company pole to the service depends upon conductor size. Consult with your Company Representative to determine the maximum distance. Temporary service must meet Company standards.
7. Customer-owned metering equipment, switching devices, conduits, conductors, luminaires, etc., are not to be mounted on Company poles.
8. Customer owned guying, when required, to be adequate for wire size and span lengths. See your Company representative for recommendations.
9. All underground temporary meter loops will be located at the transformer or at the secondary service wire at the lot line. Any variation to this standard; SEE YOUR COMPANY REPRESENTATIVE FOR RECOMMENDATIONS.

DSGN.	D.G./D.D.
DR.	K.M./D.C.L.
APPROVED BY	DATE

REQUIREMENTS FOR
TEMPORARY ELECTRIC SERVICE
CONSTRUCTION POWER



REV DATE	REV NO.
12/02/09	8
DRAWING NUMBER	
1420-TM1	

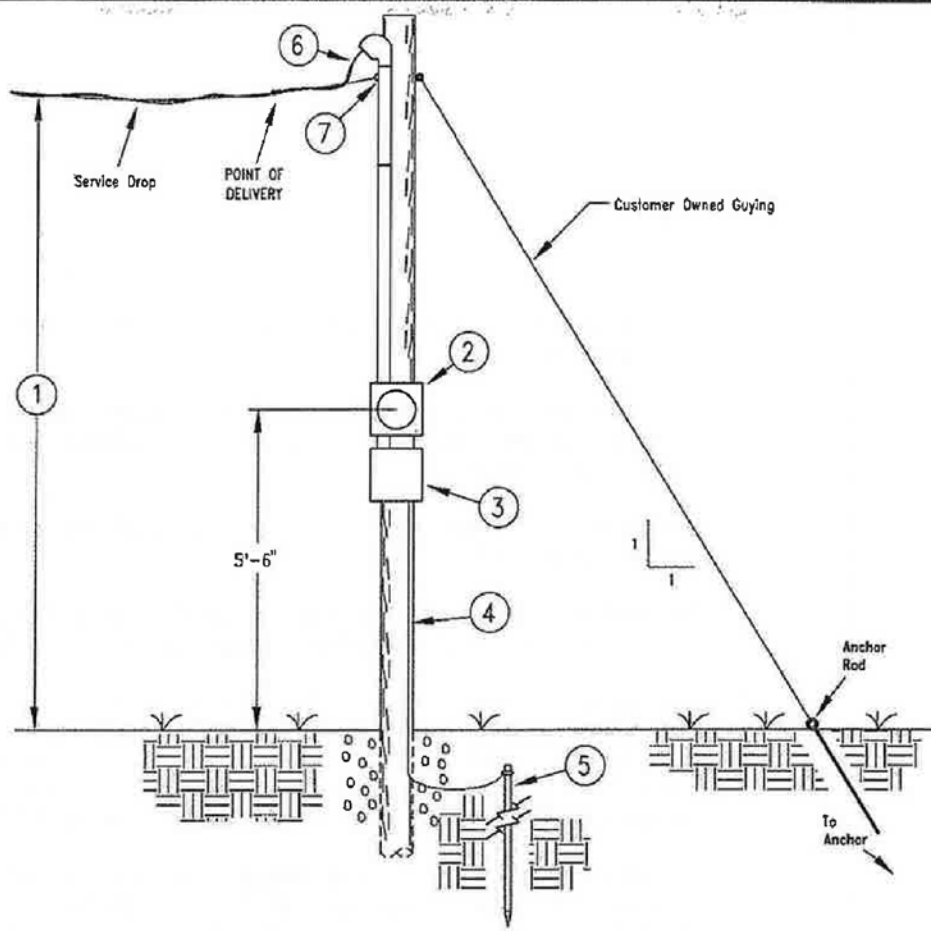

NOTES:

1. a. 10' above finished grade where all of the following conditions are met:
 - 1) Access is limited strictly to pedestrians.
 - 2) Multi-plex conductors are used.
 - 3) Conductors are 150v or less to ground.
 Pole to be minimum of 14' long, buried 3'-6", guyed as needed.
- b. 12' above grade where all of the following conditions are met:
 - 1) Residential and commercial areas not subject to truck traffic.
 - 2) Conductors are 300V or less to ground.
 Pole to be minimum of 15' long, buried 4', guyed as needed.
- c. 15' above grade where all of the following conditions are met:
 - 1) Residential and commercial areas not subject to truck traffic.
 - 2) Conductors are over 300V to ground.
 Pole to be minimum of 20' long, buried 4', guyed as needed.
- d. 18' above public streets and all other areas subject to truck traffic.
 Pole to be a minimum of 25', buried 4'-6", guyed as needed.
- e. A 6" x 6" pressure treated post or a class 6 treated pole may be used.
2. Meter can must be Company approved and installed level in all directions, Ringless Type.
3. Customer disconnect equipment must be weatherproof and have a minimum capacity 30 amperes. Switch box must be covered when inspected.
4. Ground wire - #6 copper minimum, #4 where required by NEC
5. Ground rod - 8' long by 5/8" ground rod. A butt wrapped copper ground wire is also acceptable.
6. Minimum conductor #8 copper or #6 aluminum. Must be 18" in length outside weatherhead.
7. Point of attachment for service must be provided.
8. Temporary service charges must be paid and a permit for temporary service or a wiring affidavit approving the service for connection must be obtained before service can be provided.
9. See 1410-SV1 for any other requirements.

DSGN.	D.G./D.D.
DR.	KM/DCL
APPROVED BY	DATE

TEMPORARY SERVICE
OVERHEAD
 TEMPORARY SERVICE



REV DATE	REV
12/14/11	2
DRAWING NUMBER	
1420-TM2	

The installation shall be outside the utility easement and shall not be less than 6 feet from the service pedestal or pad-mount transformer and not less than 10 feet from Company owned pole.

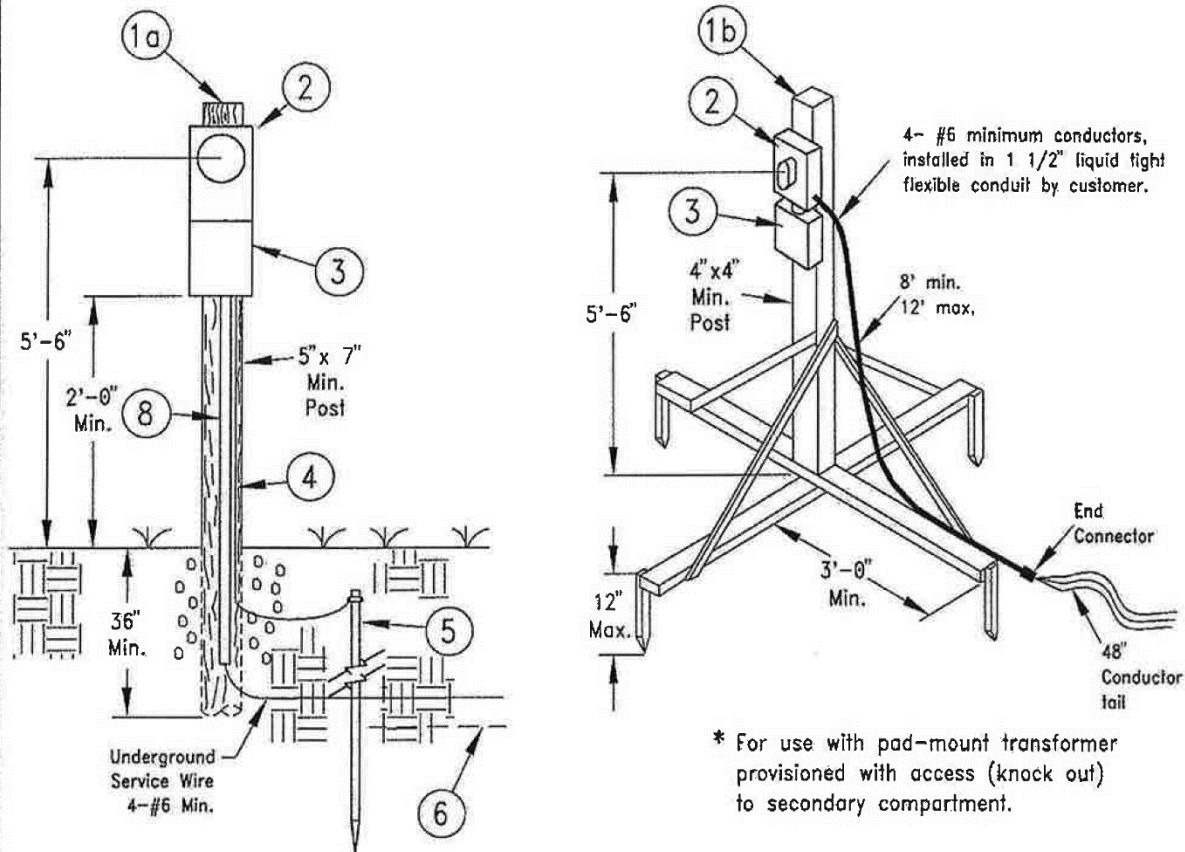

* For use with pad-mount transformer provisioned with access (knock out) to secondary compartment.

NOTES:

- 1a. - Pressure treated 5" x 7" wood post, owned by customer, to be buried 36" in ground.
- 1b. - Free standing pedestal, adequately braced and anchored. (for use with pad mount transformer)
2. Meter can must be Company approved and installed level in all directions, Ringless Type.
3. Customer disconnect equipment must be weatherproof and have a minimum capacity 30 amperes. Switch box must be covered when inspected. Installed per NEC & local utility specifications.
4. Ground wire - No. 6 copper Minimum, NO. 4 where required by NEC.
5. Ground rod -- 8' long -- 5/8" ground rod. NOTE: ground rod is not required if temp. service is adjacent to pad mount transformer where ground lead is provided from company transformer.
6. Trench according to company specifications.
7. Temporary service charges must be paid and a permit for temporary service or a wiring affidavit approving the service for connection must be obtained before service can be provided.
8. Post Conduit: 2" PVC electrical conduit to a depth 12" in ground.
9. Underground service line must be covered or back filled before service may be energized.
10. See 1410-SV1 for any other requirements.

DSGN. D.G./D.D.	TEMPORARY SERVICE	REV DATE 12/14/11	REV NO. 1
DR. KM/DCL	UNDERGROUND	DRAWING NUMBER	
APPROVED BY	TEMPORARY SERVICE	1420-TM3	
DATE		Black Hills Corporation	

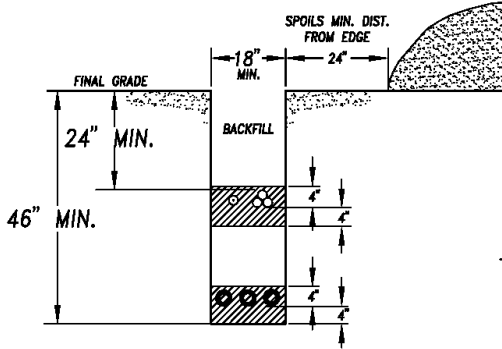

TR1
 SINGLE PHASE PRIMARY OR
 THREE PHASE PRIMARY OPTION
 SECONDARY SERVICE
 PHONE & TV

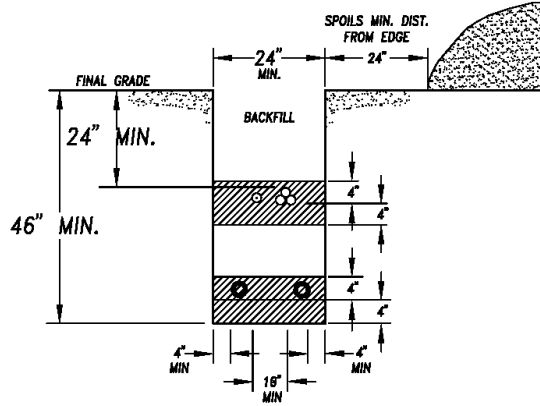

TR3
 THREE PHASE PRIMARY LOOPED
 (2 PRIMARY CONDUITS MINIMUM IN DITCH)

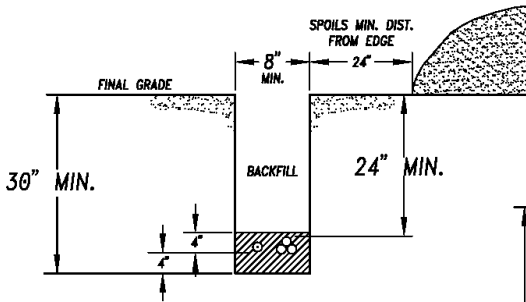

TR2
 SECONDARY SERVICE
 PHONE & TV

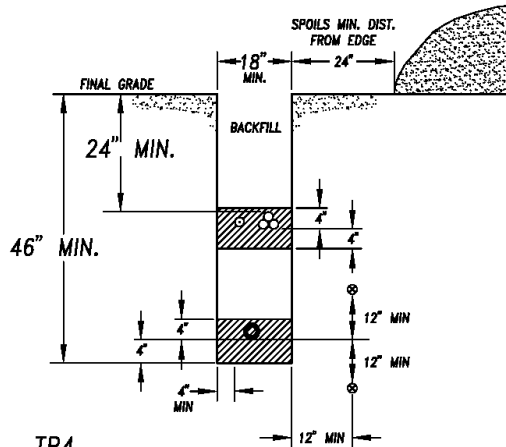

TR4
 JOINT USE - WATER OR SEWER

- LEGEND:**
- PRIMARY CONDUIT(S)
 - ⊗ SECONDARY CONDUIT(S)
 - PHONE & TV
 - ⊕ WATER OR SEWER
 - ⊙ GAS LINE

CLEAN DIRT, FINES OR SAND BACKFILL

TRENCH DEPTHS AS SHOWN ARE "MINIMUMS";
 "MAXIMUM" DEPTHS NOT TO EXCEED MINIMUMS BY MORE THAN 6".

NOTE: HORIZONTAL DISTANCE FROM FACILITIES TO WATER OR SEWER MUST BE
 48" MINIMUM WITHIN THE PLANNING JURISDICTION OF RAPID CITY.

DISGN. TM	DISTRIBUTION STANDARD TRENCH SPECIFICATIONS WITHOUT GAS BLACK HILLS ENERGY - SD	REV. DATE 9/24/2015	REV. NO. 5
DR. JLM/DCL		DRAWING NO. TR1, TR2 TR3, TR4	SHEET 1
APPROVED BY	DATE		

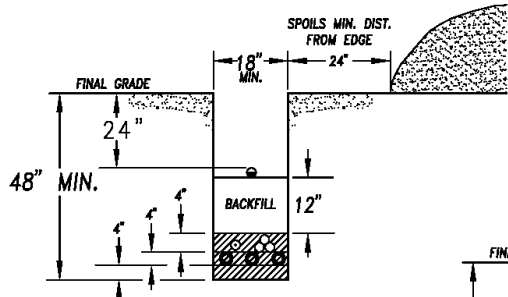

TR5
 SINGLE PHASE PRIMARY OR
 THREE PHASE PRIMARY OPTION
 SECONDARY SERVICE
 PHONE, TV & GAS

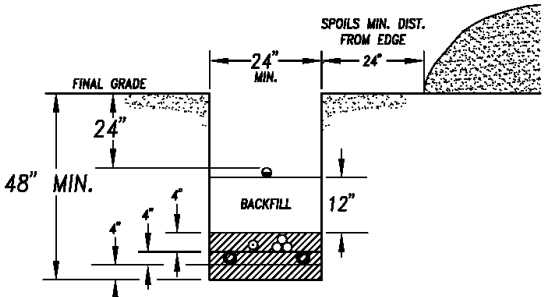

TR7
 THREE PHASE PRIMARY LOOPED
 (2 PRIMARY CONDUITS MINIMUM IN DITCH)

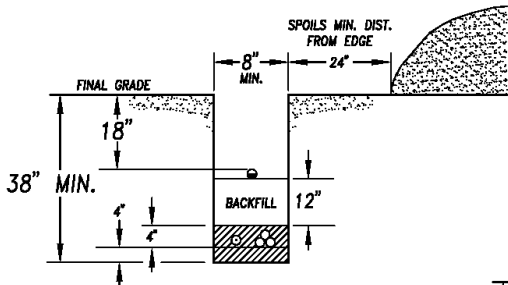

TR6
 SECONDARY SERVICE
 PHONE, TV & GAS

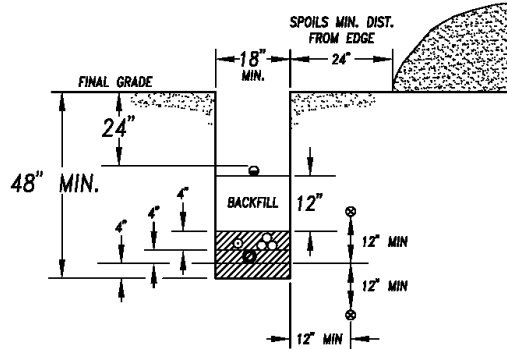

TR8
 JOINT USE - WATER OR SEWER

NOTE: HORIZONTAL DISTANCE FROM FACILITIES TO WATER OR SEWER MUST BE 48" MINIMUM WITHIN THE PLANNING JURISDICTION OF RAPID CITY.

- LEGEND:**
- PRIMARY CONDUIT(S)
 - ⊗ SECONDARY CONDUIT(S)
 - PHONE & TV
 - ⊗ WATER OR SEWER
 - GAS LINE

CLEAN DIRT, FINES OR SAND BACKFILL

TRENCH DEPTHS AS SHOWN ARE "MINIMUMS";
 "MAXIMUM" DEPTHS NOT TO EXCEED MINIMUMS BY MORE THAN 6".

DSSM TM		DISTRIBUTION STANDARD TRENCH SPECIFICATIONS JOINT WITH GAS BLACK HILLS ENERGY - SD	REV. DATE	REV. NO.
DR. JLM/DCL			9/24/2015	4
APPROVED BY	DATE		DRAWING NO.	SHEET
		TR5, TR6	1	
		TR7, TR8		

Definitions:

1. Electric utilities include power, lighting, telephone, cable t.v., signal circuits, etc.
2. Non-electric utilities include water, gas, sewer, storm drains, etc.
3. Clean dirt, fines, or sand are approved bedding material for the conduit system. Deviation from approved bedding can only be authorized by a BLACK HILLS ENERGY representative.

Trench:

1. All cable to be installed in conduit system unless approved by a BLACK HILLS ENERGY representative.
2. Clearances must be obtained from all other buried utilities before digging.
3. The conduit system should be located a minimum of two feet of the property line.
4. The conduit trench must meet the specifications of Standard Drawings TR1 thru TR8.
5. Where the surface grade of the trench location is not final, steps must be taken to ensure minimum standard depth subsequent to installation.
 - a. If the grade is to be lowered, the depth of cut must be added to our standard trench depths.
 - b. If the grade is to be raised, the trench must be standard depth at the time it is dug.
 - c. Curb and gutter must be installed in subdivisions prior to trenching to insure proper grade.
6. Back fill or bedding within 4 inches of conduit systems shall be free of all rocks or other materials that may damage the conduit. Refer to "definitions" above for standard approved material for the "cushion" around the conduit.
7. Back fill must be adequately tamped or packed to prevent sinking and meet the specifications of governmental agencies when necessary. Machine compaction must not be used within 6 inches of the conduit to prevent damage.

Conduit:

1. All conduit shall be approved HDPE black endless w/3 red stripes or PVC schedule 40 electrical conduit.
 - a. 3" conduit may be used for #2, 1/0, & 4/0 single phase primary cable.
 - b. 3" conduit shall be used for 1/0 and 4/0, residential service cable serving a 200A meter can.
 - c. 4" conduit shall be used for #2, 1/0, and 4/0 - 3 phase primary cables.
 - d. Two single phase services may be placed in one 4 inch conduit.
 - e. 6" conduit shall be used for 350KCM, 750KCM and 1000KCM primary circuits.
2. Minimum residential service cable conduit size will be 3" and standard 24" RADIUS PVC sweeps up to 150 feet, with no more than 270 degree of bends.
3. Any residential service cable conduit systems 150 feet in length or longer with 270 of bends or more need to have 24" RADIUS fiberglass sweeps installed. 200A secondary conduit systems should not exceed 280' (total wire length) or 270 degree of bends without prior approval.
4. A 1/2", 1200 lb pull tape shall be installed in all conduits.
5. Conduit ends must be sealed with Plug with PULL TABS and extend out to the ground 4 to 8 inches.
6. All primary conduit sweeps shall be FIBERGLASS with a minimum RADIUS of 48".
7. Conduit risers shall be installed in accordance with PVC molded riser drawings.
8. Schedule 80 pipe under all city, county, and state roads.

Safety:

1. Before working on primary wire, be sure there is a visible open at both ends and it is grounded, unless insulated sticks are used.
2. All enclosures, transformers and switching modules must be kept locked at all times except when actually working at their location.

Cable Installations:

1. Cable will not be placed in a conduit system unless it meets the the standard trench specification including the appropriate bedding.
2. Cable will be inspected as it is installed to insure no kinks, cuts, abrasions or damage of any kind.
3. Cable must be placed in the trench loosely, with adequate slack, and resting on the bottom of the trench for its entire length. Follow sand blasting specs TR1-TR8 on all exposed cables.
4. Be sure sufficient lengths of cable are left at the ends for risers and or terminations.
5. Cable paralleling non-electric utilities or other subsurface structures shall not be installed directly above or below such utilities. See Trench Specifications for minimum spacings.
6. Trench will be inspected prior to cable installation and prior to back filling, by BLACK HILLS ENERGY personnel.
7. Cable ends must be sealed when exposed if termination or splice is to be done at a later time. This will prevent moisture migration into the cable.

CU BOOK: S1	REVISION DATE: 3/20/19	APPROVED BY:	URD CABLE AND TRENCH GUIDELINES	DISTRIBUTION STANDARDS DRAWING # 2210	 Black Hills Energy
DRAWN BY: AP	REVISION NO.: 2	DATE:			

General:

1. All termination points of cable in transformers, switching modules and enclosures shall be clearly marked as to color coded phase and point of beginning or termination.
2. All connections, splices and terminating devices must be kept clean and dry at all times when assembling, using and storing.
3. Primary cable should not be handled when subjected to temperatures lower than 10°F in the 24 hour period preceding installation. If cold weather installation is anticipated, the cable reel should be held in a warm storage area at a temperature of at least 60°F for 24 hours prior to installation to insure total warmup.
4. The minimum bending radius of primary cables is generally 12 times the outside diameter of the cable. In the case of Kerite #2, #1/0 and #4/0 cables, 16" can be used as a minimum.
5. All primary 12.47Kv risers shall have "riser-type" lightning arresters installed. Additionally, 18Kv elbow-type arresters shall be installed at all open points in transformers or switching modules for 24.9Kv installations.
6. Underground design must meet:
 - a. ANSI-C2, National Electrical Safety Code.
 - b. National Electrical Code article 300-5 and article 710-3.

TYPICAL RESIDENTIAL SUBDIVISION - WITH PLANTER STRIP

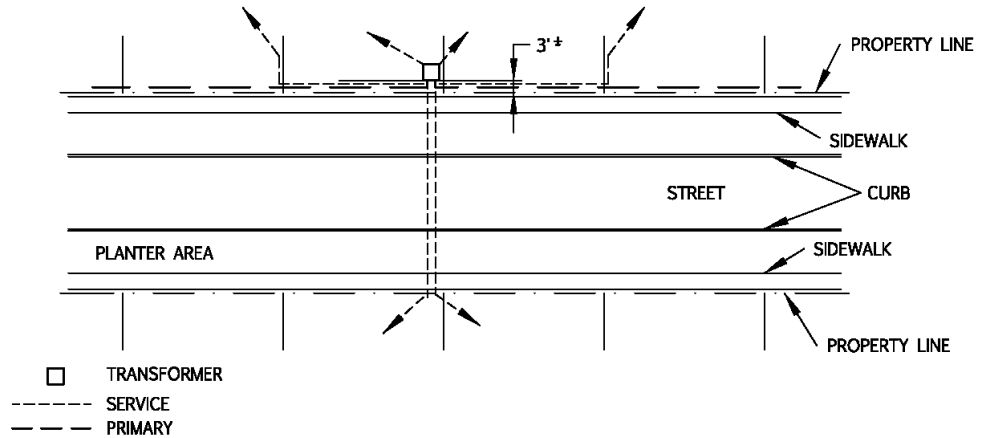

TYPICAL RESIDENTIAL SUBDIVISION - CURB SIDE SIDEWALK

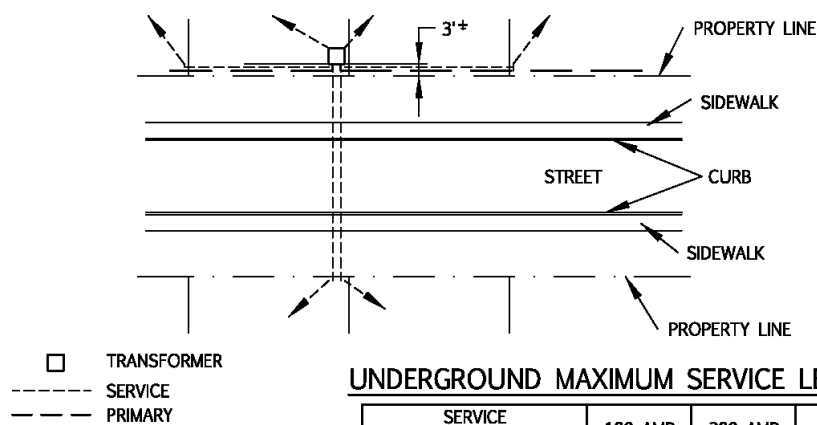

UNDERGROUND MAXIMUM SERVICE LENGTHS

SERVICE WIRE SIZE	100 AMP	200 AMP	400 AMP
1/0 TRIPLEX	300'	150'	- - -
4/0 TRIPLEX	560'	280'	140'

NOTE:

1. BHE-SD standard is a 200 or 400 amp meter socket for underground service, however the 100 amp main switch column can be used for sizing service wire, if the ultimate load will not exceed the capacity of a 100 amp main.
2. Maximum of six (6) services from a pad mounted transformer.
3. All cable in conduit. See page 1.

CU BOOK:	REVISION DATE	APPROVED BY:	URD CABLE AND TRENCH GUIDELINES	DISTRIBUTION STANDARDS	Black Hills Energy
S1	3/20/19				
DRAWN BY:	REVISION NO.	DATE	DRAWING #	2210	SHEET: 2 of 2
AP	2				



GRADE AGREEMENT

This Agreement made the _____ day of _____, 20____ between Black Hills Power, hereinafter called the Utility, and _____, hereinafter called the Developer, witnesseth:

The Utility will locate its equipment, and facilities in areas requested and designated by the Developer on the land being developed by Developer as shown on the Map or Plat of _____ which Map or Plat is hereby attached to and made a part of this Agreement. The Developer shall furnish to the Utility the final elevations and grades, which final elevations and grades shall be accurate to ±6 inches (final elevations and grades, are interpreted to mean, all work necessary prior to acceptance by homeowner). In addition, the Developer shall advise the Utility prior to commencing any excavations or grades after Utility facilities have been constructed, Developer will pay at its sole expense all costs of raising, lowering, relocating, or otherwise rearranging, repairing, or changing such facilities when in the opinion of the Utility such work is necessary to provide required clearances, stability and protection of structures or underground facilities in accordance with an applicable building or construction codes, and policies of the Utility. In the event that the Developer or any independent contractor of the Developer has not complied with the terms and conditions of this Agreement, and if damage to any existing Utility facilities occurs, the Developer shall pay all damages and loss suffered by the Utility in repairing, relocating, or replacing such facilities, including a reasonable attorney’s fee.

The Developer will establish a sufficient number of lot corners when requested by Utility in order that the Utility facilities may be placed in its proper location with respect to easement, street, or alley lines, and other utilities.

In witness whereof the aforesaid parties have hereunto by their authorized representatives set their hands and seals on the day and year first above written.

Witness or Attest:

Black Hills Power
By: _____

Developer

By: _____

SAMPLE

District _____
W.O.# _____

BLACK HILLS POWER
Application and Agreement for Electric Service Extension
State of South Dakota

Contract Number _____
Effective Date _____

The “Company” Black Hills Power and the “Applicant”

Applicants: _____
Address _____ City _____ Zip _____

Agree as follows:

- (1) The Company will install and furnish electric serve for the Customer at for a new _____ located in _____ in accordance with rates and extension rules on file with the South Dakota Public Utilities Commission.
- (2) The Applicant agrees to accept service under the following rate schedule _____ or if eliminated, the most economical and applicable remaining rate schedule for a period of not less than forty-eight (48) months from the date of initial service. That Annual Revenue from service to the Applicant as determined under Section 800 Line Extensions of the Company’s Tariffs is \$ 0.00 resulting in a Line Extension Allowance of \$0.00 of Company financed facilities (cost estimate attached).

If it is determined at any time subsequent to execution of this Application that the Applicant has changed the nature of his/her electrical service, the Line Extension Allowance shall be adjusted accordingly, which may result in a charge to the Applicant, if the construction costs exceed the correct Line Extension Allowance.

- (3) If applicable, the Applicant agrees to pay to the Company, prior to construction facilities:
 - (a) A refundable Advance Deposit subject to the rules filed by the Company for the cost of extending electric facilities beyond the Line Extension Allowance determined at (2) above. \$ _____
- (4) The Applicant shall, without cost to the Company, make or procure satisfactory conveyance to Company of right-of-way for Company’s lines necessary and incidental to the furnishing of service to Customer and for continuing, upgrading or extending said lines over and across the property owned or controlled by Applicant.
- (5) The Applicant shall, without cost to the Company, furnish a cleared right-of-way, and also grants to the Company for maintenance purposes, the right, as the Company may see fit, to cut, trim, or remove from said right-of-way any brush, trees, stumps, or roots.

SAMPLE

- (6) For underground line extensions and service laterals the Applicant will provide all trenching to the Company specifications, washed sand, or approved bedding, conduit when required, backfill, or any other restoration work required.
- (7) The Applicant will be entitled to refunds of the Advance Deposit under two (2) separate and distinct calculations:
 - (a) The Applicant may be entitled to a refund of all or part of any Advance Deposit required under paragraph (3) if additional extensions are constructed from the electric facilities requested herein. Only those line extensions which connect directly with the facilities partially financed by the Applicant, without any intervening line extensions and be considered when determining the Applicant’s entitlement of a refund. The refund will be equal to the difference between the applicable Line Extension Allowance for the new applicant and the estimated construction cost of the additional electric facilities. The Applicant will receive any applicable refund within thirty (30) days of the Applicant contacting the Company regarding the construction of additional electric facilities. The refunded Advance Deposit shall not bear interest.
 - (b) The Applicant may be entitled to a refund of all or part of any Advance Deposit required under paragraph (3) if the actual revenue from the Applicant’s account(s) served during the first four (4) years as a result of this application exceeds the Line Extension Allowance. The refunded Advance Deposit shall bear simple interest at the rate of seven (7) percent annually.

Refunds will be made only to the Applicant if still receiving service at the same location. Eligibility for refunds under (a) above is limited to four (4) years from the effective date of this agreement. Eligibility for refunds under (b) above is determined four (4) years from the effective date of this agreement. In no case shall the total refund to the Applicant exceed the amount of the Advance Deposit. Any Advance Deposit not refunded to the Applicant as set forth above shall be retained and become the property of the Company.

- (8) The refundable Advance Deposit or any portion thereof shall not be assignable by the Applicant. Payments of such refundable Advance Deposit shall continue to be made when due to the Applicant notwithstanding a transfer of the place to which electric service was extended.

Applicant

Black Hills Power Inc.

Accepted by:

Date _____

Date _____

Copies: Applicant
 Property
 G.O. Contract file
 District Office



NEW CUSTOMER QUESTION LIST

DATE OF REQUEST _____ NAME OF REQUESTER _____

PROJECT NAME _____

NAME OF PROPERTY OWNER(S) _____

PHYSICAL LOCATION OF SERVICE _____

MAILING ADDRESS OF SERVICE _____, _____, SD, _____
STREET CITY ZIP

RANGE _____ TOWNSHIP _____ SECTION _____ ¼ SECTION _____ DESCRIBED PROPERTY _____

SUBDIVISION NAME _____ LOT/BLOCK NUMBER(S) _____

MAILING ADDRESS OF OWNER _____, _____, SD, _____
STREET CITY ZIP

PHONE NUMBERS OF OWNER _____, _____, _____
CELL HOME/BUSINESS WORK

ADJACENT LAND OWNERS POWER WILL CROSS: (Please provide copies of all Plats and deeds)

NAME _____ ADDRESS _____ PHONE _____

NAME _____ ADDRESS _____ PHONE _____

NAME _____ ADDRESS _____ PHONE _____

NAME OF ELECTRICIAN _____ PHONE NUMBER OF ELECTRICIAN _____

NAME OF CONTRACTOR _____ PHONE NUMBER OF CONTRACTOR _____

NAME OF TRENCHER _____ PHONE NUMBER OF TRENCHER _____

DATE ESTIMATE IS NEEDED BY _____ DATE SERVICE NEEDED BY _____

CIRCLE ONE RESIDENTIAL OR COMMERCIAL PERMANENT OR TEMPORARY HOME GAS OR TOTAL ELECTRIC

MAIN PANEL SIZE _____ MAIN PANEL VOLTAGE _____

DATE AND TIME TO MEET AT SITE: _____

COMMENTS/CONTACTS/HISTORY _____

Note: Please call the BHE Business Office _____ to set up billing information on new service. The Business office will ask you to provide a letter of credit from your previous power provider or a deposit equal to two months revenue. All Temporary Construction Services will have an \$85 hookup fee.

Black Hills Energy

Customer Responsibilities

*Service can not be supplied until these items are completed.

- Supply BHE with courthouse copy of your plat & deed
- Supply BHE with courthouse copy of your neighbor's plat & deed (if crossing their property to serve you)
- Provide 911 address of new service to BHE
- Obtain signatures on all right-of-ways
- Sign "Electric Service Extension Agreement"
- Sign "Grade Agreement"
- Make any applicable payments
- Cut trees
- Contact other utilities; i.e. gas, telecom, cable
- Contact SD One Call, 811
- Supply proper trench, sand bedding, and backfill at appropriate time

I have received BHE's 'New Construction Handbook' and understand that any BHE related construction is to be done according to the specifications contained in the Handbook or otherwise specified by BHE personnel.

Signed: _____

Date: _____